

AVANT[®]

**VARAOSAKIRJA
PART LIST
DELLISTA
ERSATZTEILLISTE**



**AVANT 635
FROM SERIAL NUMBER
XXXXX1310**

22.11.2013

**SISÄLLYSLUETTELO
TABLE OF CONTENTS
INNEHÅLSFÖRTECKNING
INHALT**

OSAN NRO PART NO BESTALL BEST.NR	NIMITYS	DESCRIPTION	BENAMNING	BEZEICHNUNG	SIVU NRO PAGE NO	
A21561	AVANT 635 KOKOONPANO	AVANT 635	AVANT 635	AVANT 635	3 - 4	x
A35734	SUOJA KP , ETURUNKO	COVER PLATES, FRONT	SKYDDSPÅTAR, FRAMRA	VERKLEIDUNGEN, VORDE	5 - 6	x
A35821	SUOJA KP / TAKARUNKO	MOUNTING BRACKETS, C	FÄSTEN, KIT, SKYDDSP	HALTERUNGEN, VERKLEI	7 - 8	x
A35304	SUOJA KP / TAKARUNKO	COVER PLATES, REAR	SKYDDSPÅTAR, BAK, V	VERKLEIDUNGEN, HECK	9 - 9	x
A1374	ETURUNKO KP 600	FRONT FRAME, COMPLET	FRAMRAM, KOMPLETT ME	VORDERWAGEN, KOMPLE	11 - 12	x
A21558	TAKARUNKO KP	BACK FRAME, COMPLETE	BAKRAM, KOMPLETT HOP	HECKRAHMEN, KOMPLETT	13 - 14	x
A21587	HYTTI , PERUS	SAFETY FRAME, COMPLE	SÄKERHETSBJÅGE, HOPSÄ	ÜBERROLLBÜGEL, KOMPL	15 - 16	x
A21616	MOOTTORI KP D1105	ENGINE	DIESELMOTOR	DIESELMOTOR	17 - 18	x
A21226	TELESKOOPPUIPUMI KP	TELESCOPIC BOOM, COM	TELESKOPUTSKJUT, KOM	TELESKOP-HUBARM, KOM	19 - 22	x
A33932	VENTTIILI KP	CONTROL VALVE, COMPL	STYRVENTIL, KOMPLETT	STEUERGERAT, KOMPLET	23 - 24	x
A49119	ROPS + FOPS TURVAKAA	ROPS FRAME WITH FOPS	ROPS BJÅGE MED FOPS T	ROPS ÜBERROLLBÜGEL M	25 - 25	x
A414874	AJOMOOTTORI KP OMT 3	HYDRAULIC MOTOR FRON	HYDRAULMOTOR FRAM VÄ	HYDRAULIKMOTOR VORN	26 - 26	x (1)
A414876	AJOMOOTTORI KP OMT 3	HYDRAULIC MOTOR FRON	HYDRAULMOTOR FRAM HÖ	HYDRAULIKMOTOR VORN	27 - 27	x (1)
A414923	AJOMOOTTORI KP OMT 3	HYDRAULIC MOTOR REAR	HYDRAULMOTOR BAK, HO	HYDRAULIKMOTOR HINTE	28 - 28	x (1)
A34531	AJONLETKUTUS O-LOK	HYDR. HOSES, DRIVE C	HYDRAULSLANGAR, FRAM	HYDR. SCHLÄUCHE, FAH	29 - 30	x (1)
A35527	AJONLETKUTUS O-LOK	HYDR. HOSES, DRIVE C	HYDRAULSLANGAR, FRAM	HYDR. SCHLÄUCHE, FAH	31 - 32	x
A49058	AJOPOLJIN KP	DRIVE PEDAL, COMPLET	KÖRPEDAL, KOMPLETT	FAHRPEDAL, KOMPLETT	33 - 34	x
A49161	LETKUTUS AJOPOLJIN	HYDRAULIC HOSES, DRI	HYDRAULSLANGAR, KÖRP	HYDRAULIKSCHLÄUCHE,	35 - 36	x
A48998	OHJAUSPYLVÄS KP	STEERING COLUMN	STYRPELARE	LENKSÄULE	37 - 38	x
A33930	LETKUTUS ORBITROL	HYDR. HOSES, STEERIN	HYDR. SLANGAR, STYRN	HYDR. SCHLÄUCHE, LEN	39 - 40	x
A413893	HYDR.ÖLJYN JÄÄHD. ISO	HYDR. OIL COOLER, BI	HYDRAULOLJEKYLARE, S	HYDR. ÖLKÜHLER, GROS	41 - 42	x
A35461	KÄSIJARRU KP	PARKING BRAKE, COMPL	PARKERINGSBROMS, KOM	FESTSTELLBREMSE, KOM	43 - 44	x
A415984	PUNNITUSANTURI KP	LOAD SENSOR SYSTEM	LASTÖVERVAKNINGSSYST	LASTUBERWACHUNGSSY	45 - 45	x
A413932	TANKKI KP	FUEL TANK, COMPLETE	BRÄNSLETANK, KOMPLET	KRAFTSTOFFBEHALTER,	46 - 46	x
A34234	IMUYHDE KP	HYDRAULIC MANIFOLD,	HYDRAULIKBLOCK, KOMP	HYDRAULIKVERTEILER,	47 - 47	x
A34366	SARJAPIKALIITIN KP	MULTI CONNECTOR, ON	FLERSNABBKOPPLING, P	MULTI-KUPPLUNG MASC	48 - 48	x
A49124	SÄHKÖ KP	WIRE HARNESS	KABELHÄRVA	KABELBAUM	49 - 50	x
A49126	MITTARIPANEELI	DASHBOARD 500/600 SE	INSTRUMENTBRÄDA 500/	ARMATURENBRETT 500/	51 - 52	x
A34144	HYDRAULINEN VAKAAJA	BOOM SELF LEVELLING	PARALLELFÖRING	PARALLELFUHRING	53 - 54	o
A34015	KELLUNTA (VAKAAJA)	BOOM FLOATING, WITH	FLYTLÅGE, MED PARALL	SCHWIMMSTELLUNG, MIT	55 - 56	o
A47773	PUOMINKELLUNTA KP	BOOM FLOATING SYSTEM	FLYTLÅGE, BOM, 600 S	SCHWIMMSTELLUNG, HUB	57 - 58	o
A34956	HYDR. PIKAKIINNITYSLEVY	HYDRAULIC QUICK ATTA	REDSKAPSFÄSTE MED EL	GERATEANBAUPLATTE M	59 - 59	o
A412225	VAPAUTUSVENTTIILI O-LOK	DRIVE RELEASE VALVE	ELEKTR. FRIHJULKOPPL	ELEKTR. AUSGLEICHSP	60 - 60	o (1)
A35506	LUISTONESTOVENTTIILI	ANTI SLIP VALVE, WIT	ANTI SLIP VENTIL, O-	ANTI SCHLUPF VENTIL,	61 - 62	o
A34542	LUISTONESTOVENTTIILI	ANTI SLIP VALVE, WIT	ANTI SLIP VENTIL, O-	ANTI SCHLUPF VENTIL,	63 - 63	o (1)
A34014	TAKAULOSOTTO 1-TOIM	AUX. HYDR. REAR SING	HYDR. UTTAG BAK ENKE	HECKHYDRAULIK EINFAC	64 - 64	o
A47774	TAKAULOSOTTO 2-TOIM	AUX. HYDR. REAR DOUB	HYDR. UTTAG BAK, DUB	HECKHYDRAULIK DOPPEL	65 - 65	o
A35462	TAKAULOSOTTO ETEEN	EXTRA AUX. HYDR. OUT	EXTRA HYDR. UTTAG FR	VIERTER STEUERKREIS	66 - 66	o
A33658	TAKANOSTOLAITE	REAR LIFTING DEVICE	HYDRAULISK BAKLYFT	HECKAUSHEBUNG HYDRA	67 - 68	o
A33912	TIELIIKENNESARJA	ROAD TRAFFIC LIGHT K	VÄGTRAFIKBELYSNING,	KOMMUNAL/BELEUCHTUN	69 - 70	o
A34700	TYÖLÄITTEEN OHJAUS	ATTACHMENT CONTROL S	BRYTARESATS TILL ELF	SCHALTERKIT FÜR ANBA	71 - 71	o
A33916	TYÖVALOSARJA	WORK LIGHT KIT	ARBETSLJUSSATS	ARBEITSLICHTSATZ	72 - 72	o
A34917	TYÖVALOSARJA	WORK LIGHT KIT, 3 PC	ARBETSLJUSSATS, 3 ST	ARBEITSLICHTSATZ, 3	73 - 73	o
A410648	LOHKOLÄMMITIN	ENGINE BLOCK HEATER	MOTORVÄRMARE, SATS	MOTORVORWARMER, SA	74 - 74	o
-	TARRAT	DECALS	DEKALER	AUFKLEBER	75 - 78	o

(1) = SERIAL NUMBERS BETWEEN XXXXX1310 - XXXXX1341,
OMT MOTORS

x = VAKIOVARUSTE, STANDARD EQUIPMENT
o = LISÄVARUSTE, EXTRA EQUIPMENT

A21561 AVANT 635

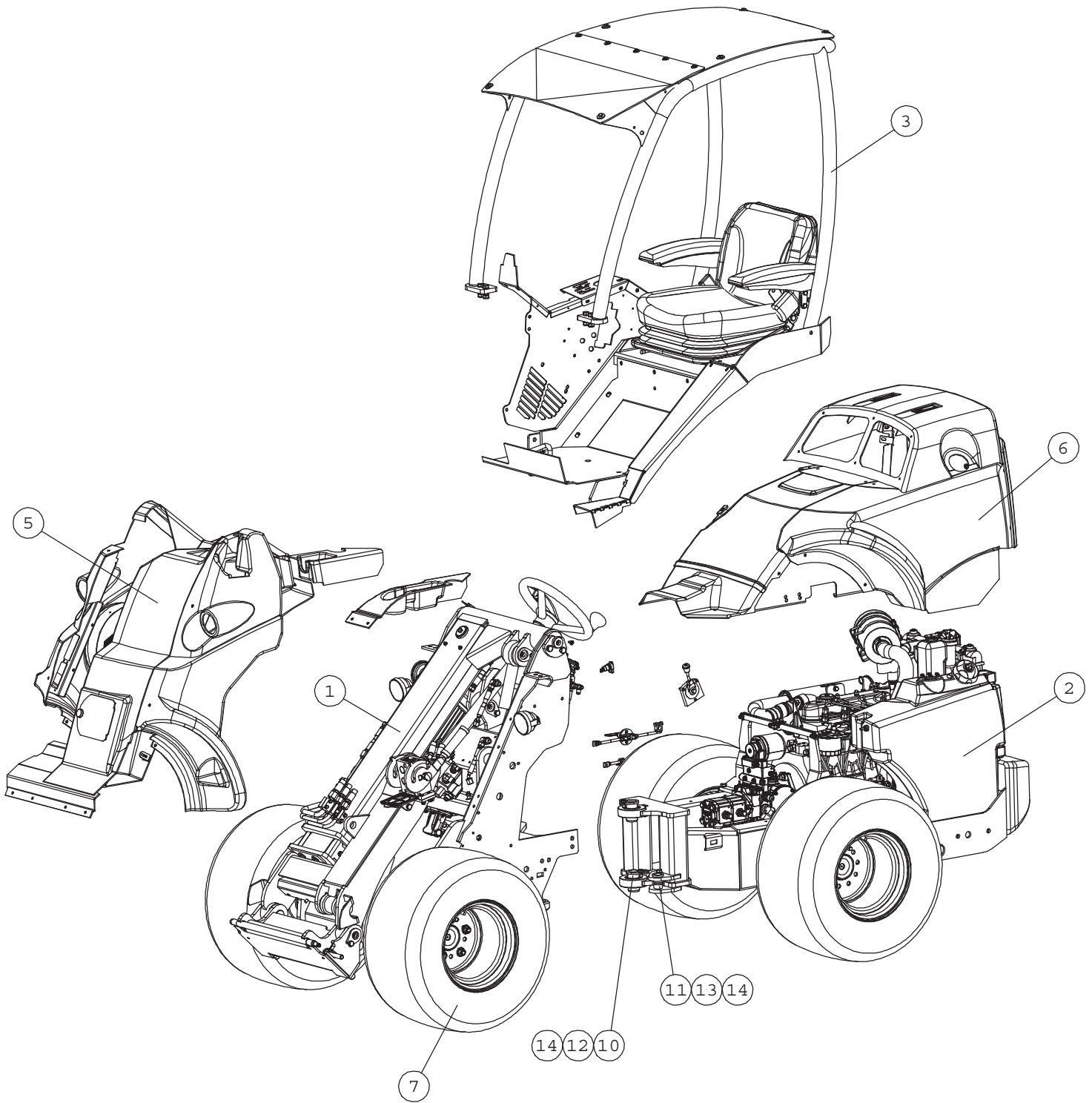

A21561 AVANT 635

NRO REF POS TEIL	OSAN NRO PART NO BESTÄLL.NR BEST.NR	KPL QTY ST ST	NIMITYS	DESCRIPTION	BENÄMNING	BEZEICHNUNG
2	A21558	1	TAKARUNKO KP	BACK FRAME, COMPLETE	BAKRAM, KOMPLETT HOP	HECKRAHMEN, KOMPLETT
3	A21587	1	HYTTI, PERUS	SAFETY FRAME, COMPLE	SAKERHETSBJÄGE, HOPSA	ÜBERROLLBÜGEL, KOMPL
4	A35527	1	LETKUTUS AJO	HYDR. HOSES, DRIVE C	HYDRAULSLANGAR, FRAM	HYDR. SCHLÄUCHE, FAH
	A34531		AJONLETKUTUS	HYDR. HOSES, DRIVE C	HYDRAULSLANGAR, FRAM	HYDR. SCHLÄUCHE, FAH
5	A35734	1	SUOJA KP, ETEEN	COVER PLATE, FRONT	SKYDDSPLÅT, FRAM, CE	VERKLEIDUNG, VORNE
6	A35821	1	SUOJA KP, TAAKSE	MOUNTING BRACKETS, C	FÄSTEN, KIT, SKYDDSP	HALTERUNGEN, VERKLEI
7	65739	4	RENGAS+VAN.10 TR.KU	WHEEL 26x12.00-12 TR	HJUL 26x12.00-12 TRA	RAD 26x12.00-12 TRAK
	65212		RENGAS+VAN.10 NURMI	WHEEL 26x12.00-12 GR	HJUL 26x12.00-12 GRÄ	RAD 26x12.00-12 RASE
	65224		RENGAS+VAN.10 TR.KU	WHEEL 10 HOLE 320/60	HJUL 10 HÅL 320/60-1	RAD 10 LOCH 320/60-1
	64930		RENGAS+VAN.6 NURMIK	WHEEL 6 BOLT 26x12.0	HJUL 6 BULT 26x12.00	RAD 6 BOLZEN 26x12.0
8	A21410	1	SÄHKÖSARJA	WIRE HARNESS, 400-70	KABELHÄRVA, 400-700	KABELBAUM, 400-700 S
9	A49124	1	SÄHKÖ KP	ELECTRIC COMPONENTS	ELEKTR. KOMPONENTER	ELEKTR. TEILE, 600 S
10	A47043	2	TAPPI KP F40-63	PIVOT PIN F40-63	AXELTAPP F40-63	GELENKBOLZEN F40-63
11	A47655	1	TAPPI KP F30-60	PIVOT PIN F30-60	AXELTAPP F30-60	GELENKBOLZEN F30-60
12	74752	2	KUUSIÖKOLORUUVI	HEXAGONAL HEAD SCREW	SEKANTHÅLSKRUV M10x	INNEN-SECHSKANTSCHR.
13	73040	1	KUUSIORUUVI ZN	HEXAGONAL SCREW M10x	SEKANTSKRUV M10x20	SECHSKANTSCHRAUBE M1
14	74531	3	ALUSLEVYPARI M10	SPACER NORDLOCK M10	BRICKA NORDLOCK M10	UNTERLEGSSCHEIBE NORD

x = before serial number XXXXX1342

A35734 COVER PLATES, FRONT, AVANT 500-600 ROPS

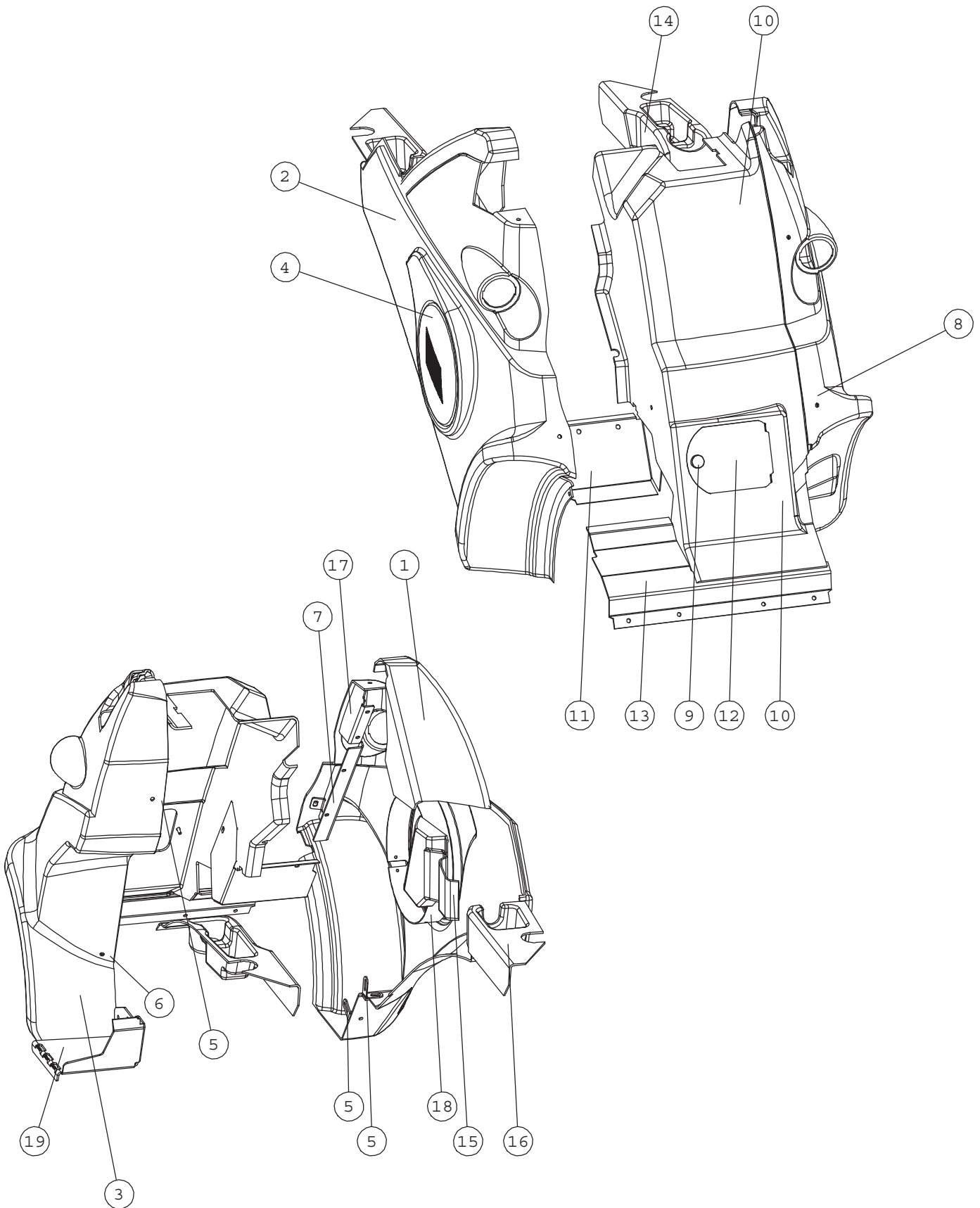

Huom! Jos kuormaaaja on varustettu L-ohjaamolla (A21592), käytä A416315
 Note! If loader is equipped with L cabin (A21592), use A416315

A35734 COVER PLATES, FRONT, AVANT 500-600 ROPS

NRO REF POS TEIL	OSAN NRO PART NO BESTÄLL.NR BEST.NR	KPL QTY ST ST	NIMITYS	DESCRIPTION	BENÄMNING	BEZEICHNUNG
1	a47719	1	PANEELI,ABS 600 (MAL	PANEL, ABS	PANEL, ABS	PANEL, ABS
2	A415754	1	ETULOKASUOJA , OIKEA	COVER PLATE, FRONT R	SKYDDSPÅT, FRAM HÖG	VERKLEIDUNG, VORNE R
3	A415759	1	SUOJA , VASEN	COVER PLATE, FRONT L	SKYDDSPÅT, FRAM VÅN	VERKLEIDUNG, VORNE L
4	A412791	1	RITILÄ	NET	NÄT	NETZ
5	A47756	3	KULMAKIINNIKE 90AST.	ANGLE BRACKET 90°	VINKELFÄSTE 90°	WINKEL-AUFNAHME 90°
6	A47677	1	KULMAKIINNIKE 110AST	BRACKET 110 DEGR, 60	FÄSTE, 110GRADER, HU	WINKEL 110 GRAD, 600
7	A415764	1	PROFIILIKANNAKE	BRACKET, FRONT RIGHT	FÄSTE, SKYDDSPÅTAR,	AUFNAHME, VORNE RECH
8	A415765	1	PROFIILIKANNAKE	BRACKET, FRONT LEFT,	FÄSTE, FRAM VÅNSTER,	AUFNAHME, VORNE LINK
9	64941	1	SORMIRUUVI RIHLATTU	FINGER SCREW M6x20 R	FINGERSKRUV M6x20 R3	FINGERSCHRAUBE M6x20
10	A412776	1	SUOJA , KESKI	COVER PLATE, CENTER	SKYDDSPÅT, MITTEN	VERKLEIDUNG, MITTE
11	A47656	1	SUOJA	COVER	LOCKPLÅT	DECKEL
12	A48000	1	HUOLTOLUUKKU	CLEANING HATCH	RENSLUCKA	REINIGUNGSÖFFNUNG
13	A414960	1	KANSI	COVER, FRONT	LOCKPLÅT, FRAM	SCHLUSSBLECH, VORNE
14	a48247	1	MUKITELINE , VASEN	CUP HOLDER, LEFT	MUGGHÅLLARE, VÅNSTER	TASSENHALTER, LINKS
15	a48251	1	KYNÄTELINE	PEN HOLDER	PENNHÅLLARE	STIFTHALTERUNG
16	a48248	1	MUKITELINE , OIKEA	CUP HOLDER, RIGHT	MUGGHÅLLARE, HÖGER	TASSENHALTER, RECHTS
17	A414801	1	REUNALEVY	EDGE PLATE	KANTSKIVA	KANTENCHEIBE
18	A416174	1	KAULUS , LYHYT	RING, SHORT	RING, KORT	RING, KURZ
19	A416318	1	ASKELMA	STEP	FOTSTEG	TRITT

A35821 REAR COVERS

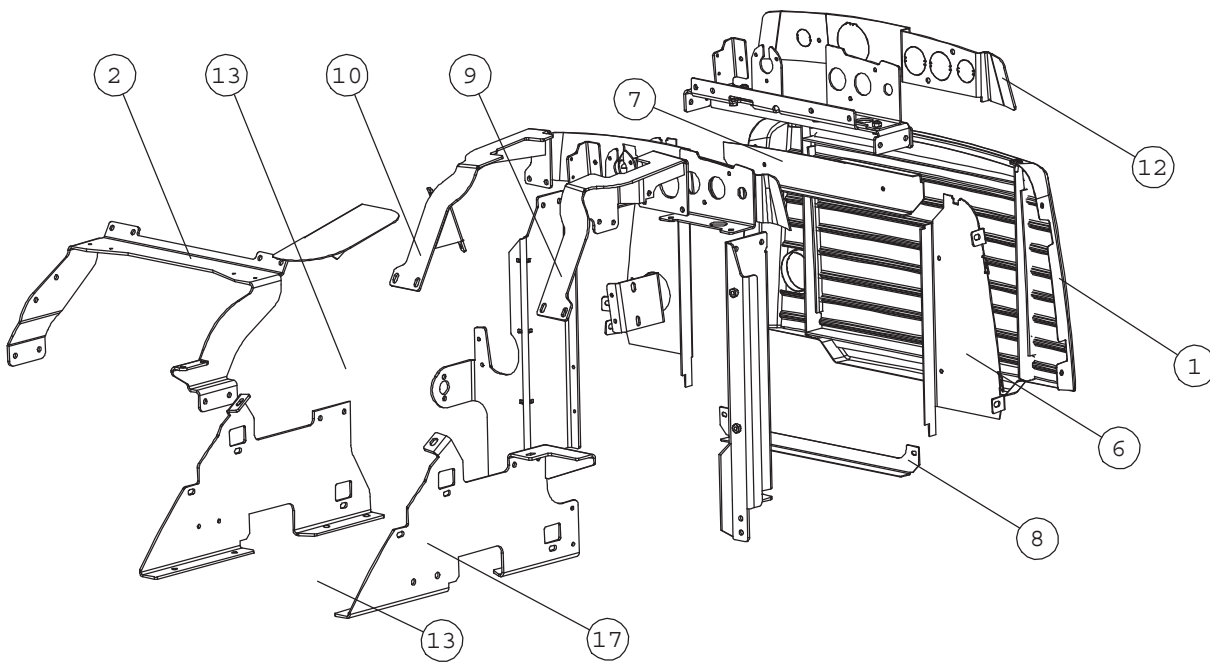
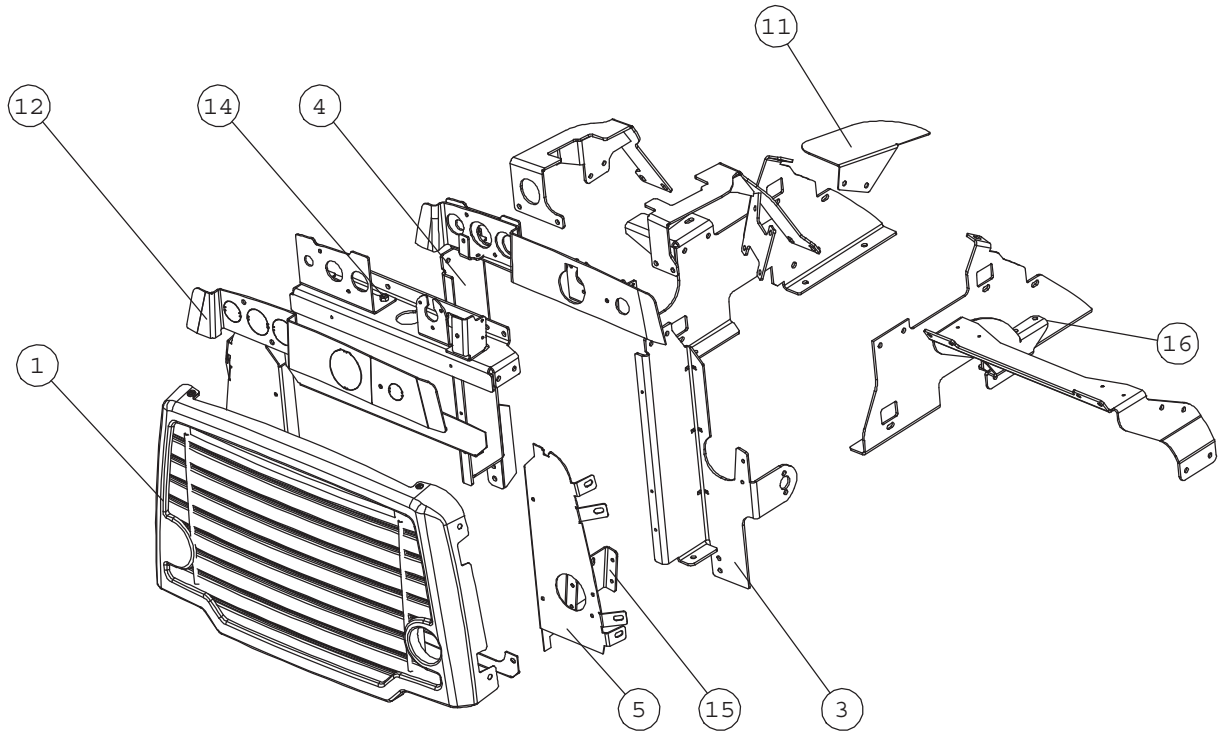

A35821 REAR COVERS

NRO REF POS TEIL	OSAN NRO PART NO BESTÄLL.NR BEST.NR	KPL QTY ST ST	NIMITYS	DESCRIPTION	BENÄMNING	BEZEICHNUNG
1	A413928	1	TAKAVERKKO KP	NET, REAR	GRILL, BAK	GITTER, HINTEN
2	A413485	1	SANKA	BRACKET	BYGEL	BÜGEL
3	A413720	1	PYSTYPALKKI , OIKEA	BEAM, VERTICAL, RIGH	BALK, VERTIKAL, HÖGE	BALKEN, VERTIKAL, RE
4	A413940	1	PYSTYPALKKI KP,VASEN	BEAM, VERTICAL, LEFT	BALK, VERTIKAL, VÄNS	BALKEN, VERTIKAL, LI
5	A413827	1	REUNALEVY , OIKEA	EDGE PLATE, RIGHT	KANTSKIVA, HÖGER	ECKSCHEIBE, RECHTS
6	A413825	1	REUNALEVY , VASEN	EDGE PLATE, LEFT	KANTSKIVA, VÄNSTER	ECKSCHEIBE, LINKS
7	A413824	1	REUNALEVY , YLÄ	EDGE PLATE, UPPER	KANTSKIVA, ÖVRE	ECKSCHEIBE, OBERE
8	A413826	1	REUNALEVY , ALA	EDGE PLATE, LOWER	KANTSKIVA, LÄGRE	ECKSCHEIBE, UNTERE
9	A413954	1	YHDYSPALKKI KP,VASEN	CONNECTING BEAM, LEF	FÖRBINDINGSBALK, VÄN	VERBINDUNGSBALKEN, L
10	A413955	1	YHDYSPALKKI KP,OIKEA	CONNECTING BEAM, RIG	FÖRBINDINGSBALK, HÖ	VERBINDUNGSBALKEN, R
11	A413871	1	LÄMPÖSUOJA	HEAT SHIELD	VÄRMESKYDD	HITZESCHILD
12	A413975	1	TAKAPANEELI	REAR PANEL	BAKANEL	HECKPLATTE
13	a35304	1	SUOJA KP	COVER PLATES, REAR,	SKYDDSPÄTAR, BAK, V	VERKLEIDUNGEN, HECK,
14	a414512	1	YLÄPALKKI KP	UPPER BEAM	ÖVERBALK	OBERBALKEN
15	a414639	1	KIINNITYSLEVY	BRACKET, EXHAUST MUF	FÄSTE, LJUDDÄMPARE	AUFNÄHME, AUSPUFF
16	A414936	1	SIVUKANNAKE , OIKEA	BRACKET, RIGHT	FÄSTE, HÖGER	AUFNAHME, RECHTS
17	A414842	1	SIVUKANNAKE , VASEN	BRACKET, LEFT	FÄSTE, VÄNSTER	AUFNAHME, LINKS

A35304 COVER PLATES, REAR, AVANT 528-640 WITHOUT MUDGUARDS

Alkaen/From/Från/Von xxxxx1210-

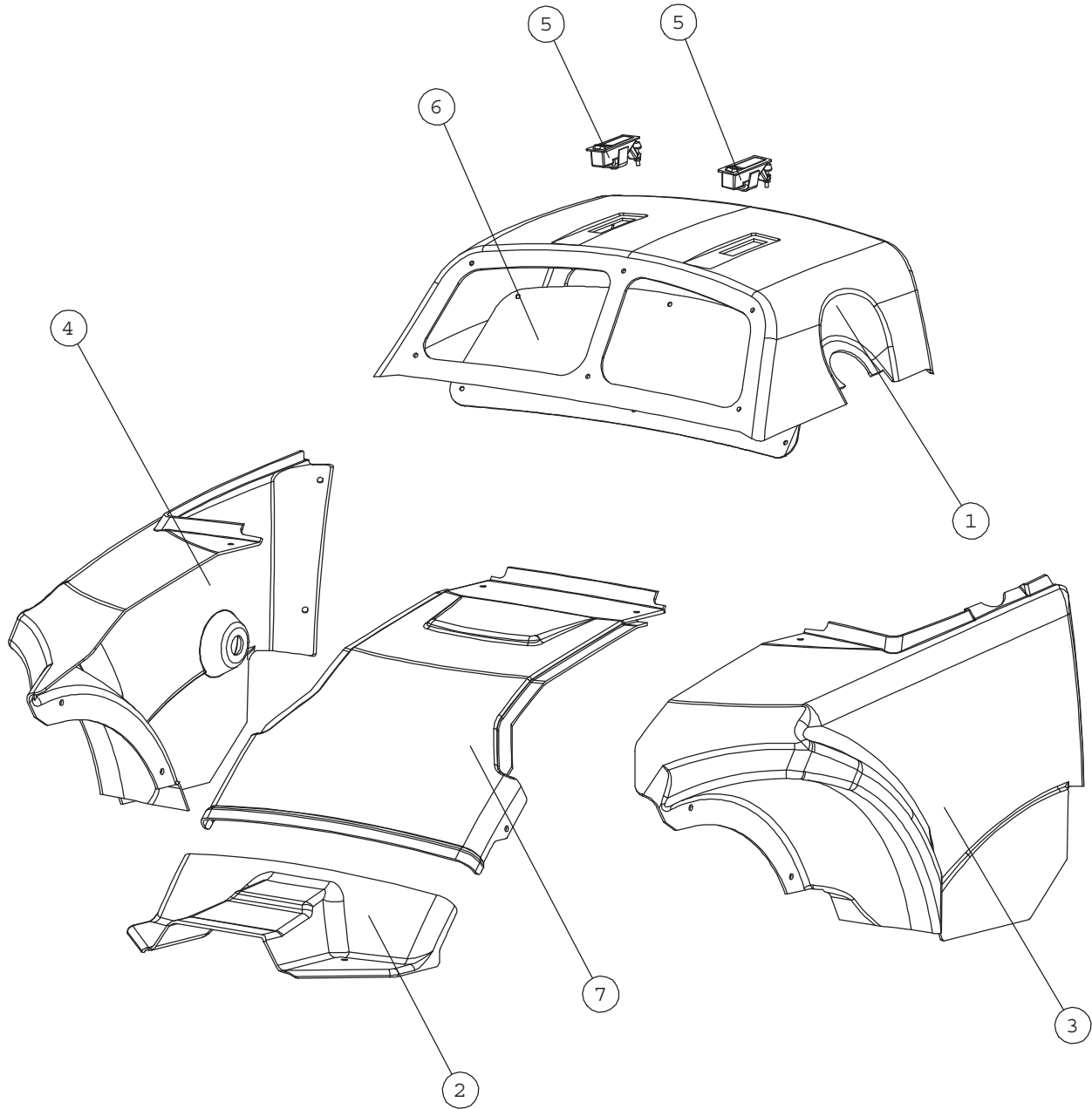

NRO REF POS TEIL	OSAN NRO PART NO BESTÄLL.NR BEST.NR	KPL QTY ST ST	NIMITYS	DESCRIPTION	BENÄMNING	BEZEICHNUNG
1	A413841	1	SUOJA , TAKA , YLÄ	COVER PLATE, ENGINE,	MOTORHUVA , 528/600 ,	MOTORHAUBE , 528/600
2	A413859	1	SUOJA , TAKA ,KESKI	COVER PLATE,CENTER,	SKYDDSPÅT BAK CENTE	VERKLEIDUNG, HINTEN
3	A413851	1	SUOJA , TAKA , VASEN	COVER PLATE, REAR, L	SKYDDSPÅT BAK VÅNST	VERKLEIDUNG, HINTEN,
4	A413888	1	SUOJA , TAKA , OIKEA	COVER PLATE REAR RIG	SKYDDSPÅT BAK HÖGER	VERKLEIDUNG HINTEN R
5	65085	2	PAINOSALPA SOUTHCO	LATCH	TRYCKLÅS	VERSCHLUSS
6	A413916	1	VERKKO, YLÄ	NET	NÅT	NETZ
7	a414701	1	SUOJA , TAKA ,KESKI	COVER PLATE, REAR, C	SKYDDSPÅT, BAK, CEN	VERKLEIDUNG, HINTEN,

A1374 FRONT FRAME, COMPLETE

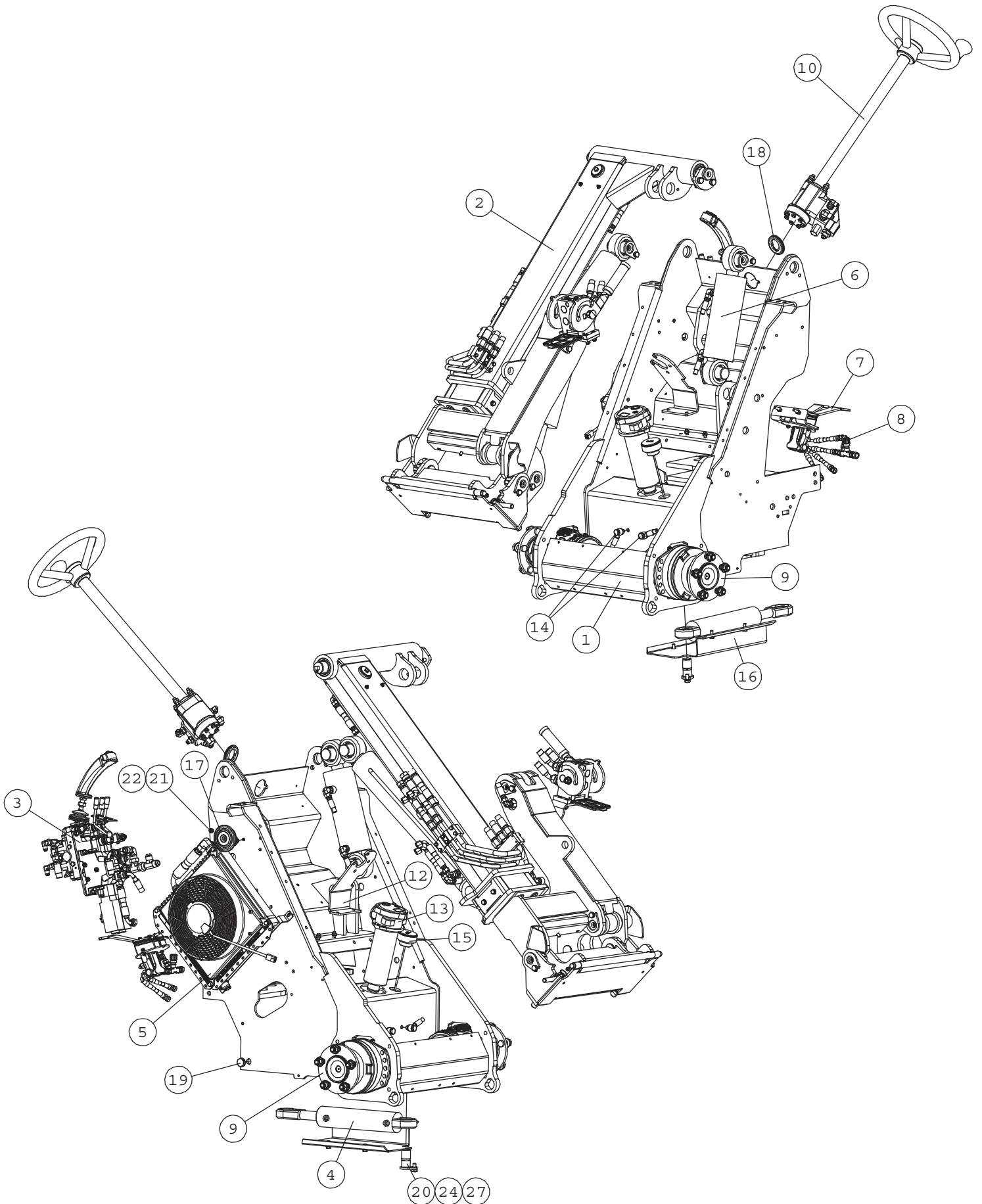

A1374 FRONT FRAME, COMPLETE

NRO REF POS TEIL	OSAN NRO PART NO BESTÄLL.NR BEST.NR	KPL QTY ST ST	NIMITYS	DESCRIPTION	BENÄMNING	BEZEICHNUNG
1	A21550	1	ETURUNKO KP	FRONT FRAME, 500/600	FRAMRAM, 500/600	VORDERWAGEN, 500/600
2	A21226	1	TELESKOOPPIPUOMI KP	TELESCOPIC BOOM, COM	TELESKOPUTSKJUT, KOM	TELESKOP-HUBARM, KOM
3	A33932	1	VENTTIILI KP	CONTROL VALVE, COMPL	STYRVENTIL, KOMPLETT	STEUERGERÄT, KOMPLET
4	A410813	1	HYDR.SYL F60/F30-172	HYDR. CYLINDER F60	HYDRAULCYLINDER F	HYDRAULIKZYLINDER
	65567		TIIVISTESARJA YAS603	SEAL KIT F60/F30	PACKNINGSSATS, CYLIN	DICHTSATZ, ZYLINDER
5	A413893	1	HYDR.ÖLJYN JÄÄHD. KP	HYDRAULIC OIL COOLER	HYDRAULÖLJEKYLARE, H	HYDRAULIKÖLKÜHLER, K
6	A34144	1	HYDRAULINEN VAKAAJA	BOOM SELF LEVELLING	PARALLELFÖRING, KOM	PARALLELFÜHRUNG, KOM
7	A49058	1	AJOPOLJIN KP	DRIVE PEDAL, COMPLET	KÖRPEDAL, KOMPLETT	FAHRPEDAL, KOMPLETT
8	A49161	1	LETKUTUS AJOPOLJIN	HYDR. HOSES, DRIVE P	HYDR. SLANGAR, KÖRPE	HYDR. SCHLÄUCHE, FAH
9	65671	2	HYDR.MOOTTORI B M	HYDRAULIC MOTOR B MS	HYDRAULMOTOR B MSE02	HYDRAULIKMOTOR B MSE
	A414874		AJOMOOTTORI KP OMT 3	HYDRAULIC MOTOR FRON	HYDRAULMOTOR FRAM VÄ	HYDRAULIKMOTOR VORNE
	A414876		AJOMOOTTORI KP OMT 3	HYDRAULIC MOTOR FRON	HYDRAULMOTOR FRAM HÖ	HYDRAULIKMOTOR VORNE
	A35461		KÄSIJARRU KP	PARKING BRAKE, ASSEM	PARKERINGSBROMS, HOP	FESTSTELLBREMSE, ZUS
10	A48998	1	OHJAUSPYLVÄS KP	STEERING COLUMN	STYRPELARE	LENKSÄULE
11	A33930	1	LETKUTUS ORBITROL	HYDR. HOSES, STEERIN	HYDR. SLANGAR, STYRN	HYDR. SCHLÄUCHE, LEN
12	A412915	1	ORBITROL-KANNAKE	BRACKET, ORBITROL	FASTE, ORBITROL	AUFNAHME, ORBITROL
13	65205	1	SUODATIN HYDR. PALUU	HYDR. OIL FILTER RET	HYDR. ÖLJEFILTER RET	HYDRAULIKÖLFILTER RÜ
	65227		SUODATINPANOS IKRON	HYDR. OIL FILTER CAR	HYDRAULÖLFILTERPATRO	HYDR. ÖLFILTEREINSAT
	64096		TERMOSTAATTIKYTKIN T	THERMOSTATIC SWITCH	TERMOSTAT 60 GRADER,	THERMOSTATSCHALTER H
14	A44054	2	VUOTOLINJA KP, ETU	DRAIN LINE, FRONT WH	LÄCKLEDNINGSSATS, FR	LECKLEITUNGSSATS, VO
15	A48010	1	MITTATIKKU-HUOHOTIN	DIPSTICK L=230 HYDR.	MÄTSTICKA L=230 HYDR	ÖLPEILSTAB L=230 HYD
16	A410452	1	POHJAPANSSARI	BOTTOM PLATE	BOTTENPLATTA	BODENPLATTE
17	64157	1	ÄÄNIMERKKI 12 V DC	SIGNAL HORN COMPLETE	SIGNALHORN KOMPLETT	HUPE KOMPLETT
18	A412961	1	LÄPIVIENTIKUMI	GROMMET	GUMMIGENOMFÖRING	GUMMIDURCHFÜHRUNG
19	64352	1	KUUSIOTULPPA R 1/2"	HEXAGONAL DRAIN PLUG	SEKKANTPROPP MAGNETI	HYDR. TANKABLASSCHRA
20	A47655	1	TAPPI KP F30-60	PIVOT PIN F30-60	AXELTAPP F30-60	GELENKBOLZEN F30-60
21	72130	7	KUUSIORUUVI ZN	HEXAGONAL SCREW M8x2	SEKKANTSKRUV M8x20 D	SECHSKANTSCHRAUBE M
22	72320	3	KUUSIOMUTTERI ZN	NUT M8 NYLOC DIN 98	SEKKANTMUTTER M8 NY	SECHSKANTMUTTER M 8
23	74767	4	UPPOK.RISTIURARUUVI	RAISED COUNTERSUNK H	KRYSSKRUV KULLERFÖRS	LINSENSENKSCHRAUBE M
24	73040	1	KUUSIORUUVI ZN	HEXAGONAL SCREW M10x	SEKKANTSKRUV M10x20	SECHSKANTSCHRAUBE M1
25	74768	4	ALUSLEVY MSS/NI M 6	WASHER MSS/NI M6	BRICKA MSS/NI M6	UNTERLEGSSCHEIBE MSS/
26	73122	4	ALUSLEVY M 8	WASHER M8 A8	BRICKA M8 A8,	UNTERLEGSSCHEIBE M8
27	74531	1	ALUSLEVYPARI M10	SPACER NORDLOCK M10	BRICKA NORDLOCK M10	UNTERLEGSSCHEIBE NORD

X
X
X

x = before serial number XXXXX1342

A21558 BACK FRAME, COMPLETE

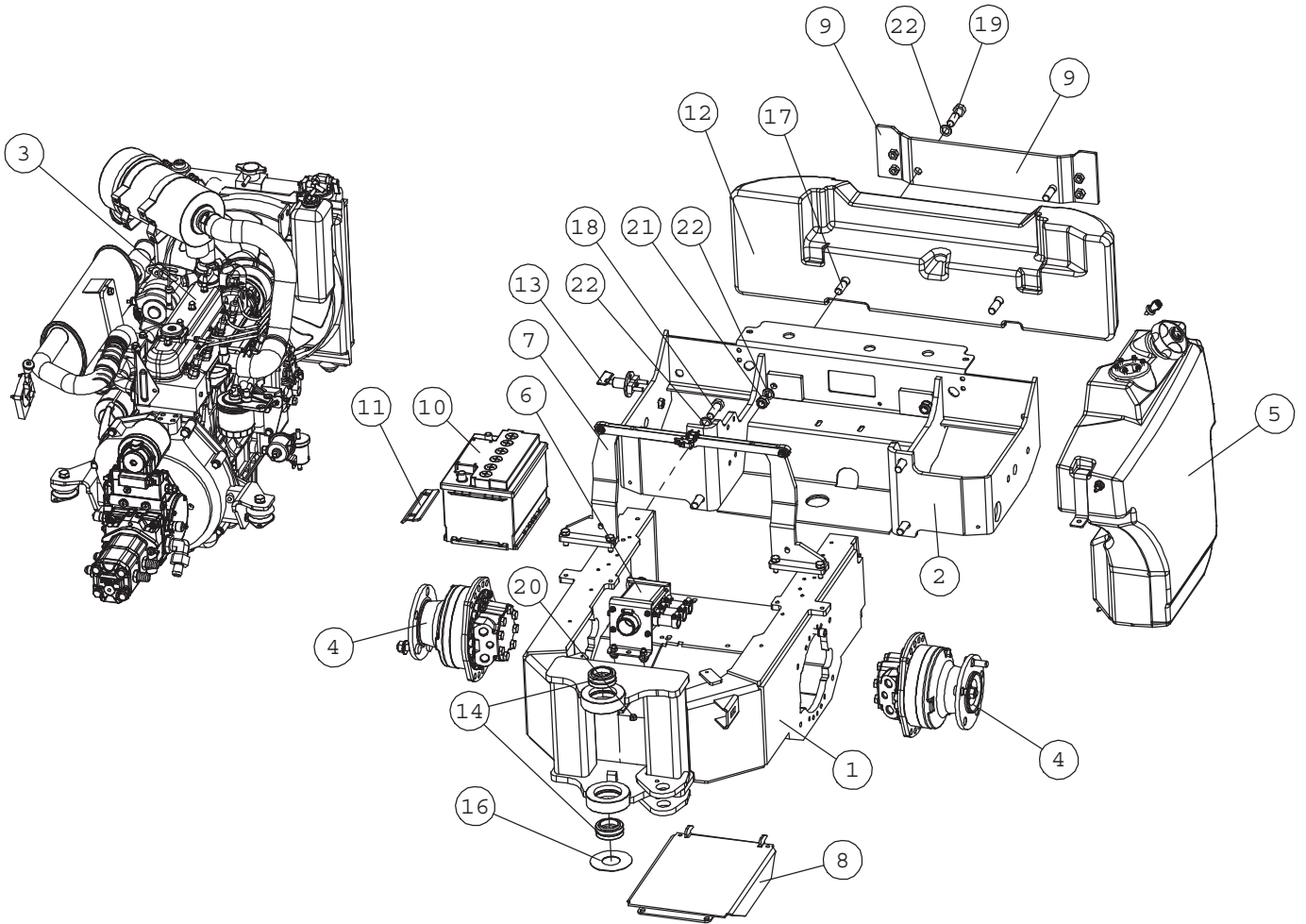

A21558 BACK FRAME, COMPLETE

NRO REF POS TEIL	OSAN NRO PART NO BESTÄLL.NR BEST.NR	KPL QTY ST ST	NIMITYS	DESCRIPTION	BENÄMNING	BEZEICHNUNG
1	A21556	1	TAKARUNKO/ETUOSA	BACK FRAME, FRONT PA	BACK FRAME, FRONT PA	HINTERRAHMEN, VORDER
2	A33331	1	TAKARUNKO KP	BACK FRAME, REAR PAR	BAKRAM, BAKDEL	HINTERRAHMEN, HINTER
3	A21616	1	MOOTTORI KP V1505	ENGINE	DIESELMOTOR	DIESELMOTOR
4	65670	2	HYDR.MOOTTORI M	HYDRAULIC MOTOR MSE0	HYDRAULMOTOR MSE02,	HYDRAULIKMOTOR MSE02
	A414923		AJOMOOTTORI KP OMT 3	HYDRAULIC MOTOR REAR	HYDRAULMOTOR BAK, HO	HYDRAULIKMOTOR HINTE
5	A413932	1	TANKKI KP	FUEL TANK, COMPLETE	BRÄNSLETANK, KOMPLET	KRAFTSTOFFBEHÄLTER,
6	A34234	1	IMUYHDE KP	HYDRAULIC MANIFOLD 7	HYDRAULBLOCK 750	HYDRAULIKVERTEILER 7
7	A415984	1	PUNNITUSANTURI KP	LOAD SENSOR SYSTEM	LASTÖVERVAKNINGSSYST	LASTÜBERWACHUNGSSYST
	A47928		PUNNITUSANTURI KP	LOAD SENSOR SYSTEM	LASTÖVERVAKNINGSSYST	LASTÜBERWACHUNGSSYST
8	A414786	1	HUOLTOLUUKKU KP	CLEANING HATCH	LOCKPLATTA, BOTTEN	REINIGUNGSKLAPPE
9	A47939	1	ADAPTERI	BRACKET, BACK WEIGHT	FÄSTE, BAKVIKT	AUFNAHMEPLATTE, HECK
10	64844	1	KÄYNNISTYSAKKU 12V	BATTERY 12V 60AH 430	BATTERI 12V 60AH 430	BATTERIE 12V 60AH 43
11	A47372	1	AKUNKIINNIKE	BRACKET, BATTERY	FASTE, BATTERI	AUFNAHME, BATTERIE
12	A33489	1	TAKAPAINO 172KG	BACK WEIGHT 172 KG	BAKVIKT 172 KG	HECKGEWICHT 172 KG
13	64141	1	PÄÄVIRTAKYTKIN	BATTERY DISCONNECT S	HUVUDSTRÖMBRYTARE C-	HAUPTSCHALTER C-1802
14	64911	2	NIVELLAAKERI	ARTICUL. BEARING GE4	LEDLAGER GE40ES F62/	GELENKLAGER GE40ES F
15	74415	1	RUUVINIPPA	SCREW NIPPLE 128.244	SKRUVNIPPEL 128.244	SCHRAUBENNIPPEL 128.
16	A48263	1	SOVITUSPRIKKA S=1MM	WASHER S=1 MM, JOINT	BRICKA S=1 MM, MIDJA	UNTERLEGSSCHEIBE S=1
17	74494	2	KUUSIORUUVI ZN	HEXAGONAL SCREW M16x	SEKKANTSKRUV M16x80	SECHSKANTSCHRAUBE M1
18	72193	4	KUUSIORUUVI ZN	HEXAGONAL SCREW M16x	SEKKANTSKRUV M16x 50	SECHSKANTSCHRAUBE M1
19	74493	2	KUUSIORUUVI ZN	HEXAGONAL SCREW M16	SEKKANTSKRUV M16x60	SECHSKANTSCHRAUBE M1
20	73040	2	KUUSIORUUVI ZN	HEXAGONAL SCREW M10x	SEKKANTSKRUV M10x20	SECHSKANTSCHRAUBE M1
21	72330	8	KUUSIOMUTTERI	HEXAGONAL NUT M16 NY	SEKKANTMUTTER M16 NY	SECHSKANTMUTTER M16
22	74533	16	ALUSLEVYPARI M16	WASHER, PAIR, M16 NL	BRICKA, PAR, M16 NL1	UNTERLEGSSCHEIBE, PAA

x = before serial number XXXXX1342

A21587 SAFETY FRAME, COMPLETE

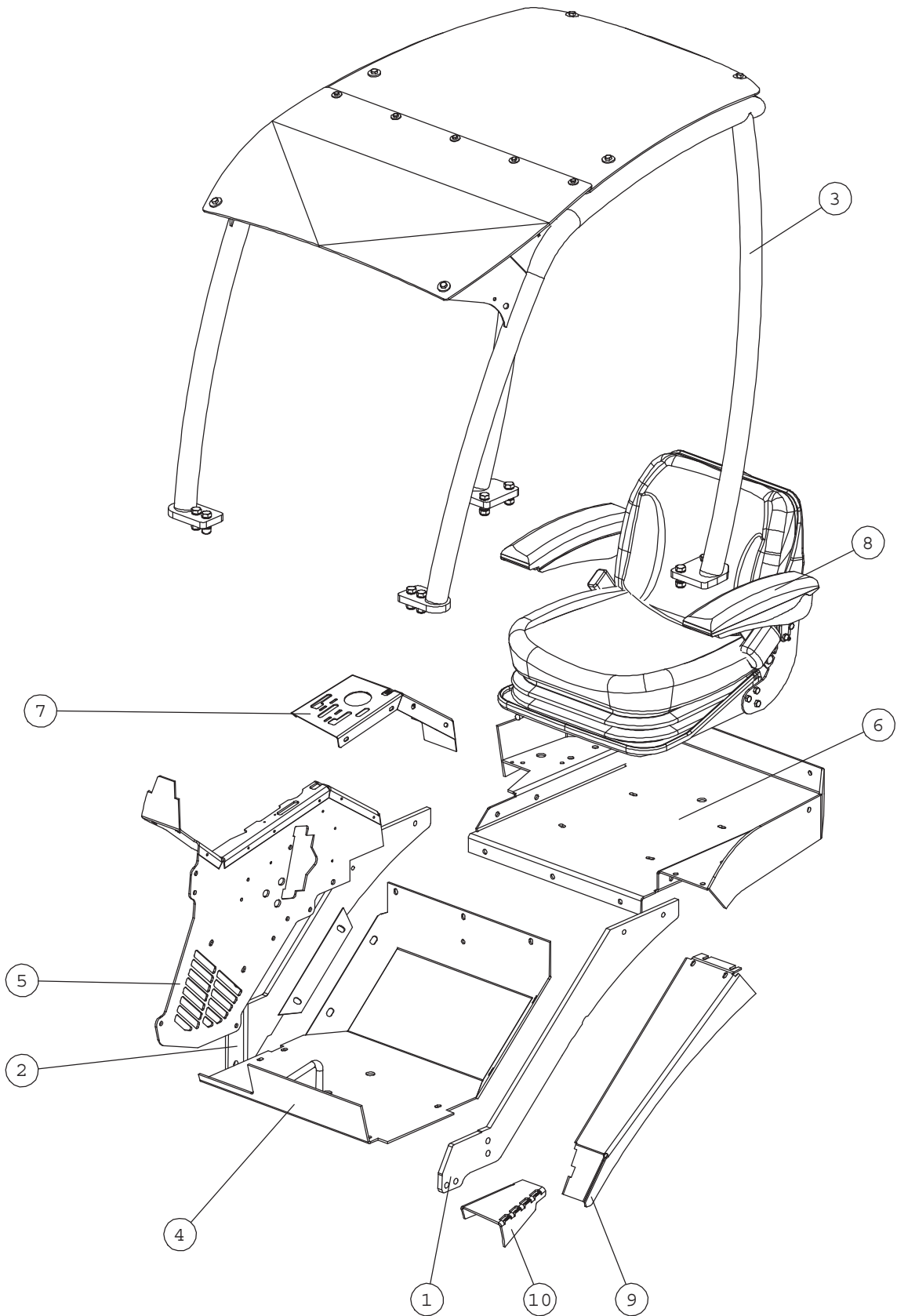

A21587 SAFETY FRAME, COMPLETE

NRO REF POS TEIL	OSAN NRO PART NO BESTÄLL.NR BEST.NR	KPL QTY ST ST	NIMITYS	DESCRIPTION	BENÄMNING	BEZEICHNUNG
1	A47834	1	AISA , VASEN KP	BAR, LEFT	STÅNG, VÄNSTER	STANGE, LINKS
2	A47389	1	AISA , OIKEA KP	BAR, RIGHT	STÅNG, HÖGER	STANGE, RECHTS
3	A49119	1	ROPS + FOPS TURVAKAA	ROPS FRAME WITH FOPS	ROPS BÄGE MED FOPS T	ROPS ÜBERROLLBÜGEL M
4	A47399	1	POHJA KP	FLOOR PLATE	GOLVPLATTA	FUSSBODEN-PLATTE
5	A48069	1	SIVULEVY KP	SIDE PLATE	SIDOPLATTA	SEITENPLATTE
6	A48246	1	ISTUINKAUKALO	SEAT BASE	SITSRAM	SITZRAHMEN
7	A48838	1	PANEELI	COVER PLATE, CONTROL	SKYDDSPLÅT, REGLAGE	ABDECKBLECH, STEUERH
8	64853	1	ISTUIN, JOUSITET LÄM	SEAT, WITH SUSPENSIO	SITS, FJÄDRAD, MED V	SITZ, GEFEDERTER, MI
9	65780	1	ISTUINOSA + LÄMMITIN	BOTTOM SEAT + HEATER	SITSDYNA, GRÖN MED V	SITZKISSEN, GRÜN MIT
9	A47531	1	REUNASUOJA	EDGE PLATE	KANTSKYDD	KANTENSCHUTZ
10	A415798	1	ASKELMA	STEP	FOTSTEG	AUFTRITT

A21616 ENGINE

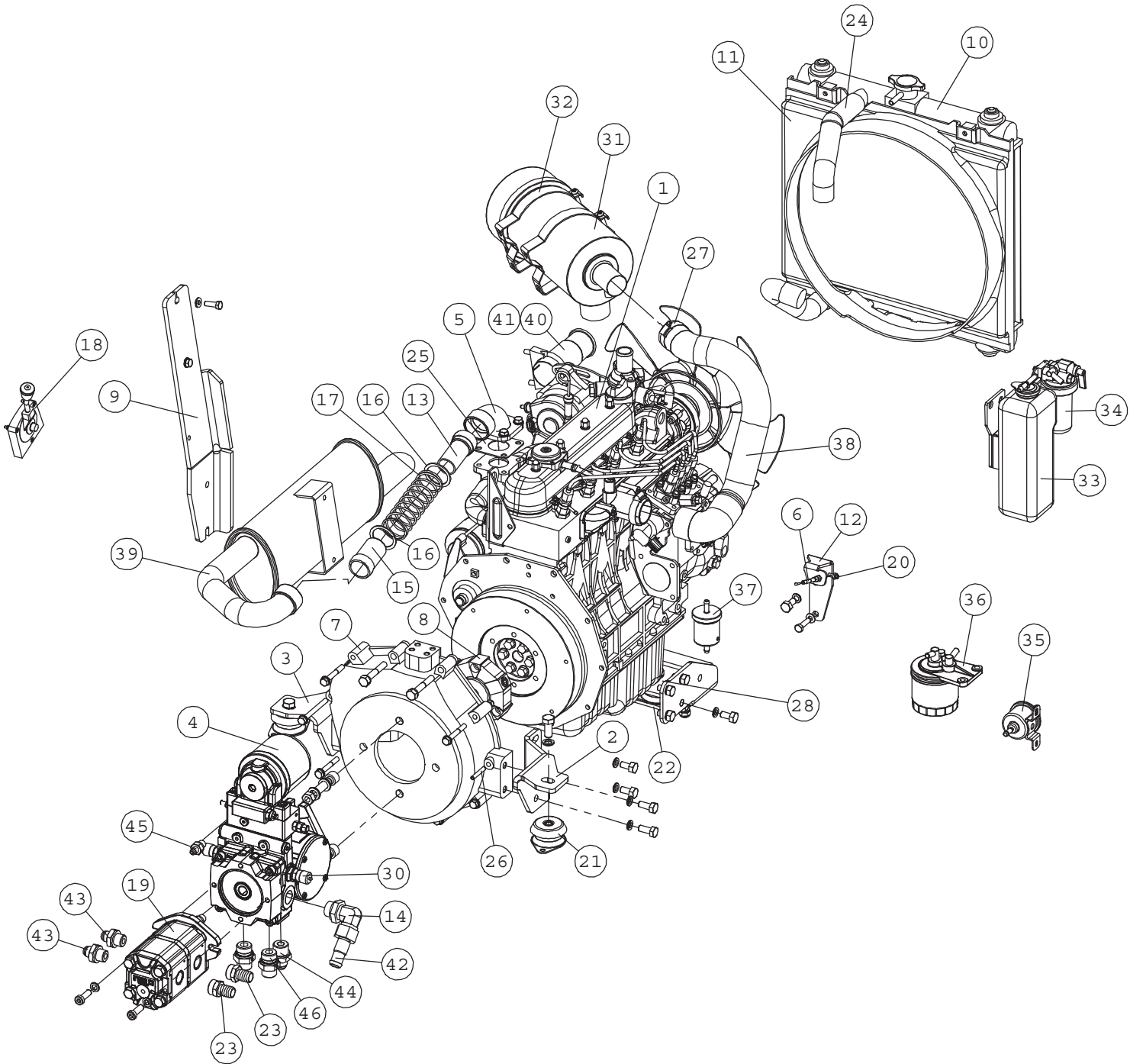

A21616 ENGINE

NRO REF POS TEIL	OSAN NRO PART NO BESTÄLL.NR BEST.NR	KPL QTY ST ST	NIMITYS	DESCRIPTION	BENÄMNING	BEZEICHNUNG
1	64921		POLTTOM EI JAAHD KUB	DIESEL ENGINE KUBOTA	DIESELMOTOR KUBOTA V	DIESELMOTOR KUBOTA V
	65145		LATURI KUBOTA 40 A	ALTERNATOR KUBOTA 40	GENERATOR KUBOTA 40A	LICHTMASCHINE KUBOTA
	64627		ÖLJYNSUODATIN 16271-	ENGINE OIL FILTER KU	MOTORÖLJEFILTER KUBO	MOTORÖLFILTER KUBOTA
2	A415138	1	MOOTTORINKORVAKE	MOUNTING BRACKET, EN	FÄSTE, MOTOR, VÄNSTE	MOTORHALTERUNG, LINK
3	A415139	1	MOOTTORINKORVAKE	MOUNTING BRACKET, EN	FÄSTE, MOTOR, HÖGER	MOTORHALTERUNG, RECH
4	65704	1	SÄÄTÖTILAV.PUMPPU M4	VARIABLE DISPL. PUMP	VARIABEL KOLVPUMP	VERSTELLPUMPE
	64807		SUODATIN BONDIOLI&PA	PRESSURE FILTER, HYD	TRYCKFILTER, HYDRAUL	DRUCKFILTER, HYDRAUL
	64917		SÄÄTÖTILAV.PUMPP M4P	VARIABLE DISPL PUMP	VARIABEL KOLVPUMP B&	VERSTELLPUMPE B&P M4
5	A47259	1	PAKOSARJA 635(MOOTTO	EXHAUST PIPE, ENGINE	AVGASRÖR, MOTORSIDA,	AUSPUFFROHR, MOTOREN
6	A47712	1	KAASUVAJERI AVANT 6	THROTTLE WIRE L=3000	GASVAJER L=3000/270	BOWDENZUG L=3000/270
7	64691	1	KYTKINKOTELO EAK4984	FLYWHEEL HOUSING EAK	KOPPLINGSBUS EAK4984	SCHWUNGRADGEHÄUSE EA
8	64690	1	VÄLIKYYTK. PUOLIKAS	COUPLING EAK4921 16/	MELLANKOPPLING EAK49	KUPPLUNG EAK4921 16/
9	A48364	1	PAKOPUTKEN KANNAKE	BRACKET, EXHAUST MUF	FÄSTE, LJUDDÄMPARE/A	AUFNAHME, AUSPUFF
10	64926	1	JÄÄHDYTIMEN KUBOTA KIT	RADIATOR, KIT, KUBOT	KYLARE, SATS, KUBOTA	KÜHLER, SATZ, KUBOTA
	65405		PAINEKORKKI JÄÄHD.	CAP, RADIATOR KUBOTA	VIPPBRYTARE, SVART,	WIPPSCHALTER, SCHWAR
11	a33333	1	JÄÄHDYTTIMEN KAULUS	FRAME, RADIATOR, 635	RAM, KYLARE, 635	RAHMEN, KÜHLER, 635
12	A47999	1	KAASUVAIJ.KANNAKE	BRACKET, GAS WIRE	FÄSTE, GASVAJER	AUFNAHME, BOWDENZUG
13	A46003	1	PAKOPUTKEN SISAOSA	EXHAUST PIPE, INNER	AVGASRÖR, INRE	AUSPUFF, INNERER
14	65683	1	KULMALIITIN 90 AST.	ELBOW FITTING 45 DEG	VINKELKOPPLING 45 GR	WINKEL-VERSCHR. 45 G
15	A46004	1	PAKOPUTKEN ULKO-OSA	EXHAUST PIPE, OUTER	AVGASRÖR, YTTRE	AUSPUFF, AUSSERER
16	A46002	2	RENGAS	RING	RING	RING
17	A46005	1	JOUSI 3x41x140 NT 8,	SPRING 3x41x140 nt 8	FJÄDER 3x41x140 nt 8	FEDER 3x41x140 nt 8,
18	73762	1	SÄÄTÖLAITE	HAND THROTTLE CONTRO	HANDGASREGLAGE F7110	HANDGASHEBEL, KOMPLE
19	64916	1	HYDR. PUMPPU HPLPB	HYDRAULIC PUMP BONDI	HYDRAULPUMP BONDIOLI	HYDRAULIKPUMPE BONDI
20	74415	1	RUUVINIPPA	SCREW NIPPLE 128.244	SKRUVNIPPEL 128.244	SCHRAUBENNIPPEL 128.
21	64843	3	TÄRINÄNERISTIN N	ENGINE MOUNT NOVIBRA	VIBRATIONSÄMPARE NO	MOTORLAGERUNGSGUMMI
22	a46783	1	VÄLIADAPTERI	MOUNTING PLATE	MONTERINGSPLATTA	AUFNAHMEPLATTE
23	64915	2	LETUKUKARA	HOSE FITTING R3/4"UK	SLANGKOPPLING R3/4"U	SCHLAUCHNIPPEL R3/4"
24	A47758	1	YLÄVESILETKU V1505	WATER HOSE, UPPER	VATTENSLANG, ÖVRE	WASSERSCHLAUCH, OBER
25	64280	1	PAKOSARJAN TIIVISTE	SEAL, EXHAUST PIPE	PACKNING, AVGASRÖR,	DICHTUNG, AUSPUFF, K
26	71793	1	JOUSISOKKA	SPRING COTTER PIN 6	FJÄDERSPRINT 6x 40	FEDERSPLINT 6 x 40
27	64338	2	LETUKUNIRISTIN ABA	HOSE CLAMP ABA 44-56	SLANGKLÄMMA ABA 44-5	SCHLAUCHKLEMME ABA 4
28	A47252	1	MOOTTORINKORVAKE, T	MOUNTING BRACKET, EN	MOTORFÄSTE, BAK, 600	AUFNAHME, MOTOR, HIN
29	A410456	1	SAMMUTUSSOLENOIDIN	WIRE HARNESS, STOP S	KABELHÄRVA STOPPSOLE	KABELBAUM, STOP SOLE
30	64196	2	MITTAUSPIKALIITIN	MANOMETER FITTING M1	MANOMETERKOPPLING M1	MANOMETERSCHNELLVERS
31	64923	1	ILMANSUODATIN	AIR FILTER VIRGIS /	LUFTFILTER VIRGIS FC	LUFTFILTER VIRGIS FC
	64956		ILMANSUODATINPANOS UL	AIR FILTER ELEMENT C	LUFTFILTERPATRON CHO	LUFTFILTEREINSATZ CH
	65229		ILMANSUODATINPANOS SIS	AIR FILTER, INNER SC	LUFTFILTER, INRE SÄK	LUFTFILTEREINSATZ, I
32	64925	2	KIINNITYSPANTA	CLAMP, AIR FILTER	KLÄMMARE, LUFTFILTER	KLEMME, LUFTFILTER
33	65067	1	PAISUNTASÄILIÖ KUBOT	OVERFLOW BOTTLE 1,30	EXPANSIONSTANK 1,30	ÜBERLAUF KUBOTA 1,30
34	64920	1	VEDENEROTIN KIT424	WATER SEPARATOR, KIT	VATTENSEPARATOR,SATS	WASSERSEPARATOR, SAT
35	64625	1	POLTTOA SIIRTOPUMPPU	FUEL PUMP ELECTR. KU	BRÄNSLEPUMP ELEKTR.	KRAFTSTOFFPUMPE ELEK
36	64868	1	POLTTOAINESUODATIN K	FUEL FILTER, KIT 166	BRÄNSLEFILTER, KIT 1	KRAFTSTOFFFILTER, KI
	64626		POLTTOAINESUODATINPA	FUEL FILTER KUBOTA 1	BRÄNSLEFILTER KUBOTA	KRAFTSTOFFFILTER KUBO
37	64657	1	POLTTOAINESUODATINP.	FUEL FILTER IN HOSE	BRÄNSLEFILTER I SLAN	KRAFTSTOFFFILTER IM S
38	a413619	1	IMULETKU	INLET HOSE	SUGSLANG	EINSAUGSCHLAUCH
39	a35261	1	PAKOPUTKI	EXHAUST MUFFLER	LJUDDÄMPARE	AUSPUFF
40	65598	1	PAKOPUTKENPÄÄ	EXHAUST TRIM, MUFFLE	ÄNDRÖR, KROMAD, AVGA	ENDRÖHRBLENDE, AUSPU
41	74853	1	PAKOPUTKEN SIDE	CLAMP, EXHAUST MUFFL	KLÄMMARE, AVGASRÖR	KLEMME, AUSPUFF
42	A43056	1	LETUKUKARA	HOSE FITTING MULTI	SLANGKOPPLING MULTI	SCHLAUCHKUPPLUNG MUL
43	64058	2	PERUSLIITIN	BASIC FITTING F40XS1	RAK KOPPLING F40XS12	GERADE EINSCHRAUBVER
44	64692	1	PERUSLIITIN	BASIC FITTING F40XS1	RAK KOPPLING F40XS16	GERADE EINSCHR. F40X
45	64678	2	PERUSLIITIN	BASIC FITTING F40XS6	RAK KOPPLING F40XS6-	GERADE EINSCHR. VERS
46	65313	2	PERUSLIITIN	BASIC FITTING 10-12F	RAK KOPPLING 10-12F4	GERADE EINSCHR. VERS

x = before serial number XXXXX1342

A21226 TELESCOPIC BOOM

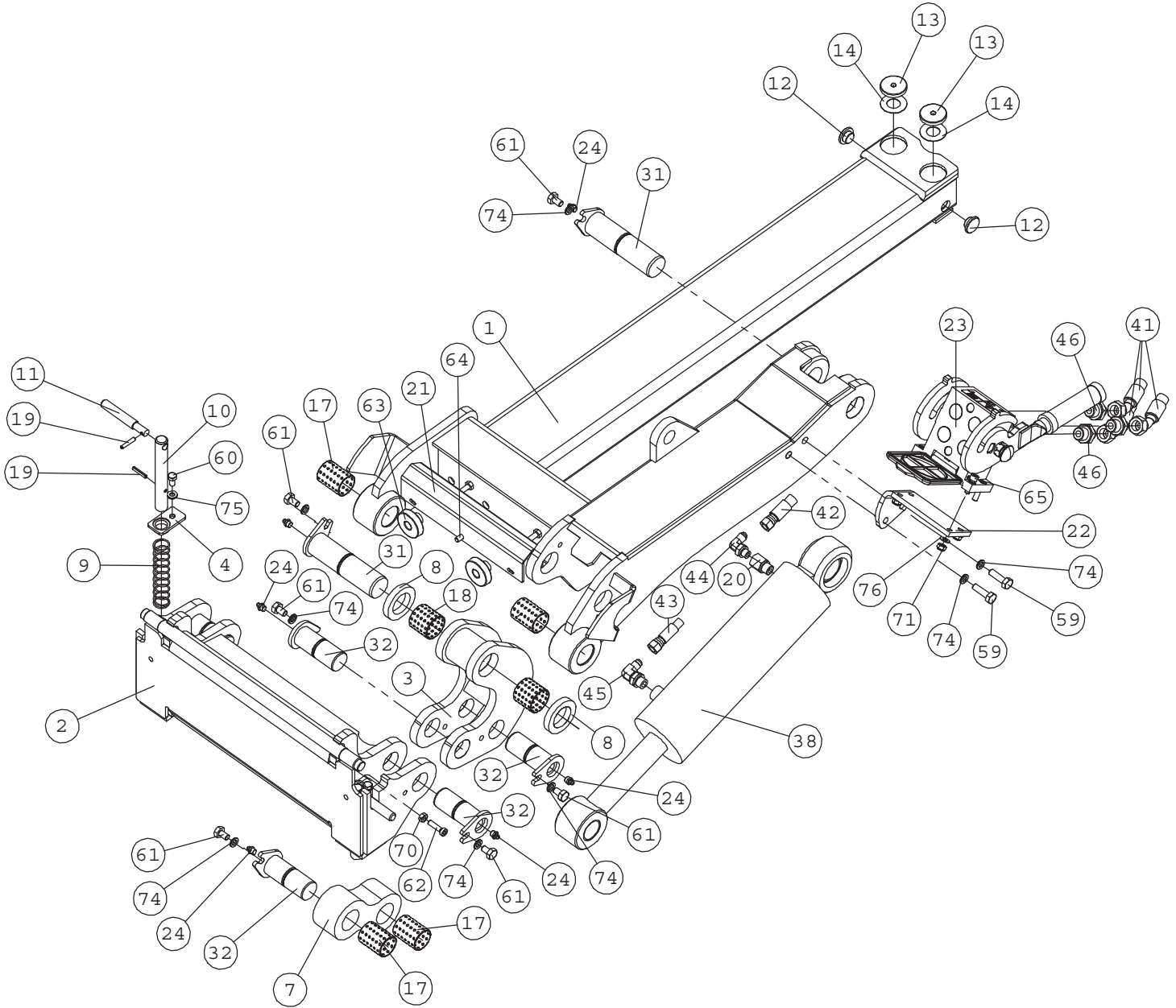

A21226 TELESCOPIC BOOM

NRO REF POS TEIL	OSAN NRO PART NO BESTÄLL.NR BEST.NR	KPL QTY ST ST	NIMITYS	DESCRIPTION	BENÄMNING	BEZEICHNUNG
2	A33292	1	PIKAKIINNITYSLEVY	ATTACHMENT COUPLING	REDSKAPSFÄSTE	GERÄTEANBAUPLATTE
3	A47000	1	BOMERANG KP	LINKAGE PIECE ("BOOM	LÄNKJÄRN ("BUMERANG"	GELENKTEIL ("BUMERAN
4	A47691	2	OHJAIN KP	GUIDE	FÄSTE	LEITSTÜCK
7	A46999	1	YHDYSKAPPALE	LINKAGE PIECE	LÄNKJÄRN	GELENKTEIL
8	A47069	2	VÄLIPRIKKA	WASHER	BRICKA	UNTERLEGSSCHEIBE
9	64138	2	PURISTUSJOUSI, DIN	COMPRESSION SPRIG DI	TILLHÅLLARFJADER DIN	DRUCKFEDER DIN 2098
10	A47687	2	LUKITUSTAPPI F20	LOCKING PIN F20	LÄSTAPP F20	VERRIEGELUNGSBOLZEN
11	A47688	2	VIRITYSTAPPI	LATCH PIN	ÄDRAGNINGSTAPP	GRIFFBOLZEN
12	A48343	2	LIUKURULLA	ROLLER, BOOM	GLIDRULLE, TELESKOPU	GLEITROLLE, HUBARM
13	A47922	2	LIUKURULLA	ROLLER, BOOM	GLIDRULLE, TELESKOPU	GLEITROLLE, HUBARM
14	A47941	2	LIUKULEVY	SLIDE PLATE	GLIDPLATTA	GLEITPLATTE
17	64913	4	LIUKULAAKERI BRM-80	SLIDE BEARING BRM-80	GLIDLAGER BRM-80 TFP	GLEITLAGER BRM-80 TF
18	64912	2	LIUKULAAKERI BRM-80	SLIDE BEARING BRM-80	GLIDLAGER BRM-80 TFP	GLEITLAGER BRM-80 TF
19	73661	4	JOUSISOKKA	SPRING PIN 5x30 DI	FJÄDERSPRINT 5x30	SICHERUNGSSPLINT 5x3
20	64324	3	SUPISTIN	REDUCER FITTING RI 3	FÖRMINSKNINGSKOPPLIN	REDUZIERVERSCHRAUBUN
21	a413816	1	HUOLTOTUKI	SERVICE SUPPORT, LIF	STÖDJÄRN, LYFTCYLIND	HUBARMABSTÜTZUNG
22	A410804	1	PIKALIITIN KIINNIKE	MOUNTING BRACKET, MU	FÄSTE, FLERSNABBKOPP	AUFNAHME, MULTI-KUPPL
23	65252	1	PIKALIITINRYHMÄ 3P5	MULTI CONNECTOR, ON	FLERSNABBKOPPLING, L	MULTI-KUPPLUNG, LADE
24	72798	13	RASVANIPPA DIN 71412	GREASE NIPPLE R 1/8	SMÖRJNIPPEL R 1/8"	SCHMIERNIPPEL R1/8
31	A47042	2	TAPPI KP F40-147	PIVOT PIN F40-147	AXELTAPP F40-147	GELENKBOLZEN F40-147
32	A47040	5	TAPPI KP F35-88	PIVOT PIN F35-88	AXELTAPP F35-88	GELENKBOLZEN F35-88
38	A47921	1	HYDR.SYL F90/F40-216	HYDR. CYLINDER F90/F	HYDRAULCYLINDER F90/	HYDR. ZYLINDER F90/F
	65005		TIIVISTESARJA YAS904	SEAL KIT, CYLINDER 9	PACKNINGSSATS CYLIND	DICHTSATZ, ZYLINDER
41	A414911	3	HYDR.LETKU L=1150 2L	HYDR. HOSE L=1150	HYDRAULSLANG L=115	HYDR. SCHLAUCH L=115
42	A414912	1	HYDR.LETKU L=1250 2L	HYDR. HOSE L=1250	HYDRAULSLANG L=125	HYDR. SCHLAUCH L=12
43	A414913	1	HYDR.LETKU L=1550 2L	HYDR. HOSE L=1550	HYDRAULSLANG L=1550	HYDR. SCHLAUCH L=15
44	64087	3	KULMALIITIN 90 AST.	ELBOW FITTING 90 DEG	VINKELKOPPLING 90 GR	WINKEL-VERSCHR. C40X
45	64044	2	KULMALIITIN 90 AST	ELBOW FITTING 90 DE	VINKELKOPPLING 90 GR	WINKEL EINSCHR. C40X
46	64058	3	PERUSLIITIN	BASIC FITTING F40XS1	RAK KOPPLING F40XS12	GERADE EINSCHRAUBVER
59	74505	2	KUUSIORUUVI ZN	HEXAGONAL SCREW M10x	SEKKANTSKRUV M10x35	SECHSKANTSCHRAUBE M1
60	73039	8	KUUSIORUUVI ZN	HEXAGONAL SCREW M 8	SEKKANTSKRUV M 8x16	SECHSKANTSCHRAUBE M
61	72147	9	KUUSIORUUVI ZN	HEXAGONAL SCREW M 10	SEKKANTSKRUV M 10x16	SECHSKANTSCHRAUBE M
62	73100	2	KUUSIOKOLORUUVI	HEXAGONAL SCREW M8x3	SEKKANTHÄLSKRUV M8x3	INNENSECHSKANT - SCH
63	64188	2	SORMIRUUVI RIHLATTU	FINGER SCREW R5026M8	FINGERSKRUV R5206M8S	FINGERSCHRAUBE R5026
64	72139	1	KUUSIORUUVI ZN	HEXAGONAL SCREW M 8	SEKKANTSKRUV M 8x6	SECHSKANTSCHRAUBE M
65	71884	4	KUUSIOKOLORUUVI	HEXAGONAL SCREW M	SEKKANTHÄLSKRUV M	INNENSECHSKANT - SCH
70	72319	2	KUUSIOMUTTERI ZN	HEXAGONAL NUT M8 DI	SEKKANTMUTTER M8 DIN	SECHSKANTMUTTER M8 D
71	72320	5	KUUSIOMUTTERI ZN	NUT M8 NYLOC DIN 98	SEKKANTMUTTER M8 NY	SECHSKANTMUTTER M 8
74	74531	11	ALUSLEVYPARI M10	SPACER NORDLOCK M10,	BRICKA NORDLOCK M10,	UNTERLEGSSCHEIBE NORD
75	63944	6	ALUSLEVYPARI M 8	WASHER, PAIR, NORD-L	BRICKA NORD-LOCK M8,	UNTERLEGSSCHEIBE, PAA
76	73122	4	ALUSLEVY M 8	WASHER M8 A8	BRICKA M8 A8,	UNTERLEGSSCHEIBE M8

A21226 TELESCOPIC BOOM

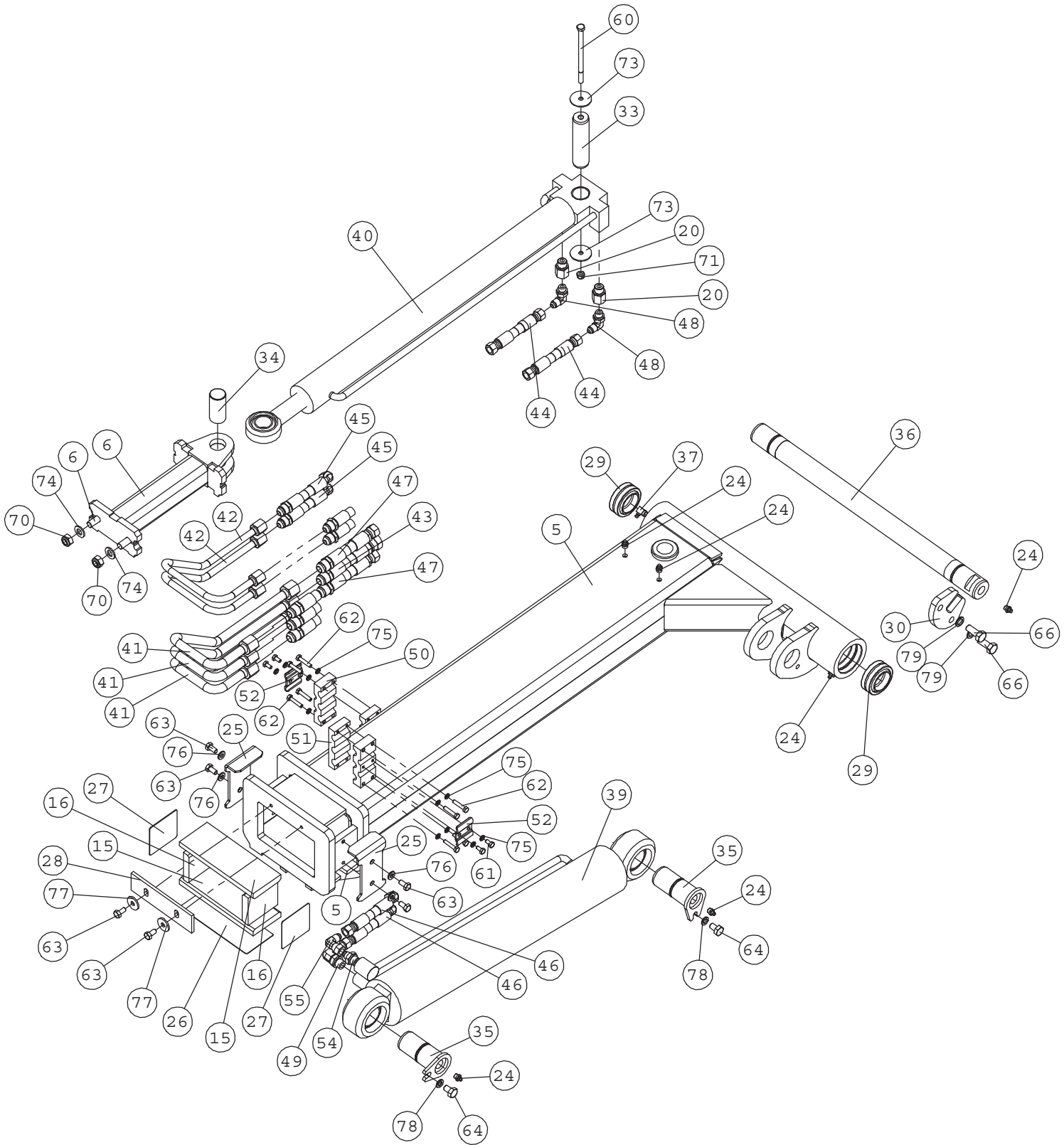

A21226 TELESCOPIC BOOM

NRO REF POS TEIL	OSAN NRO PART NO BESTÄLL.NR BEST.NR	KPL QTY ST ST	NIMITYS	DESCRIPTION	BENÄMNING	BEZEICHNUNG
5	A33604	1	TYVIJUOMI HITS.KP	OUTER BOOM	YTTRE BOM	HUBARM, ÄUSSERER
6	A47002	1	TYÖNTÖTANKO KP	LINKAGE ROD, SELF LE	LÄNKSTÄNG, PARALLELL	GELENKSTANGE, PARALL
15	A48339	2	LIUKUPALA 15x72x194	SLIDE PAD 15x72x194	GLIDPLATTA 15x72x194	GLEITSTÜCK 15x72x194
16	A48340	2	LIUKUPALA 15x72x78	SLIDE PAD 15x72x78	GLIDPLATTA 15x72x78	GLEITSTÜCK 15x72x78
20	64324	3	SUPISTIN	REDUCER FITTING RI 3	FÖRMINSKNINGSKOPPLIN	REDUZIERVERSCHRAUBUN
24	72798	13	RASVANIPPA DIN 71412	GREASE NIPPLE R 1/8	SMÖRJNIPPEL R 1/8"	SCHMIERNIPPEL R1/8
25	A48341	2	PEITELEVY	MOUNTING PLATE, SLID	STÖDPLATTA, GLIDSTYC	ABDECKPLATTE, GLEITS
26	A48014	2	SÄÄTÖPELTI 1MM , PIT	ADJUSTMENT PLATE 1 M	JUSTERINGSPLATTA 1 M	EINSTELLPLATTE 1 MM,
27	A48013	2	SÄÄTÖPELTI 1MM , LYH	ADJUSTMENT PLATE 1 M	JUSTERINGSPLATTA 1 M	EINSTELLPLATTE 1 MM,
28	A48367	1	KAAVIN	SCRAPER	SKRAPA	SCHABER
29	64911	2	NIVELLAAKERI	ARTICUL. BEARING GE4	LEDLAGER GE40ES F62/	GELENKLAGER GE40ES F
30	a49723	1	TELKILEVY	LOCKING PLATE	SÄKRINGSPLATTA	SICHERUNGSPLATTE
33	A48489	1	TAPPI F30	PIVOT PIN F30	AXELTAPP F30	GELENKBOLZEN F30
34	A47692	1	TAPPI F30-66	PIVOT PIN F30-66	AXELTAPP F30-66	GELENKBOLZEN F30-66
35	A47041	2	TAPPI KP F40-90	PIVON PIN F40-90	AXELTAPP F40-90	GELENKBOLZEN F40-90
36	a49725	1	TAPPI F40-564	PIVOT PIN F40-564	AXELTAPP F40-564	GELENKBOLZEN F40-564
37	74082	1	RASVANIPPA	GREASE NIPPLE R1/8"	SMÖRJNIPPEL R1/8" 90	SCHMIERNIPPEL R1/8"
39	A47031	1	HYDR.SYL F80/F40-450	HYDR. CYLINDER F80/F	HYDR. CYL. F80/F40-4	HYDR. ZYLINDER F80/F
	65002		TIIVISTESARJA YAS804	SEAL KIT, 80/40CYLI	TÄTNINGSSATS 80/40 C	DICHTSATZ, 80/40 ZY
40	A47032	1	HYDR.SYL F50/F32-600	HYDR. CYLINDER F50/F	HYDRAULCYLINDER F50/	HYDRAULIKZYLINDER F5
	65004		TIIVISTESARJA YAS503	SEAL KIT 50/32 CYLIN	PACKNINGSSATS 50/32	DICHTSATZ 50/32 ZYLI
41	A47559	3	HYDRAULIPUTKI F16	HYDRAULIC PIPE F16	HYDRAULRÖR F16	HYDRAULIKROHR F16
42	A47560	2	HYDRAULIPUTKI F12	HYDRAULIC PIPE F12	HYDRAULRÖR F12	HYDRAULIKROHR F12
43	A47681	1	HYDR.LETKU L=1020 1L	HYDR. HOSE L=1020 1L	HYDRAULSLANG L=1020	HYDR. SCHLAUCH L=102
44	A47637	2	HYDR.LETKU L=1300 2L	HYDR. HOSE L=1300 2L	HYDRAULSLANG L=1300	HYDR. SCHLAUCH L=130
45	A47638	2	HYDR.LETKU L=1610 2L	HYDR. HOSE L=1610 2L	HYDRAULSLANG L=1610	HYDR. SCHLAUCH L=161
46	A47635	2	HYDR.LETKU L=1720 2L	HYDR. HOSE L=1720 2L	HYDRAULSLANG L=1720	HYDR. SCHLAUCH L=172
47	a47639	2	HYDR.LETKU L=1100 2L	HYDR. HOSE L=1100 2L	HYDRAULSLANG L=1100	HYDR. SCHLAUCH L=110
48	64087	3	KULMALIITIN 90 AST.	ELBOW FITTING 90 DEG	VINKELKOPPLING 90 GR	WINKEL-VERSCHR. C40X
49	64044	2	KULMALIITIN 90 AST	ELBOW FITTING 90 DE	VINKELKOPPLING 90 GR	WINKEL EINSCHR. C40X
50	A47562	1	HYDR.PUTKEN F16/F12	BRACKET, HYDR.PIPE F	RÖRKLÄMMARE F16/F12	ROHRKLEMME F16/F12
51	A47561	1	HYDR.PUTKEN F16 KANN	BRACKET, HYDR. PIPE	FÄSTE, HYDRAULRÖR F1	ROHRENKLEMME, HYDR.
52	A47563	2	HYDR.PUTKEN F12 KA	BRACKET, HYDR.PIPE F	RÖRKLÄMMARE F12	ROHRKLEMME F12
54	64041	1	PERUSLIITIN	BASIC FITTING F40X	RAK KOPPLING F40XS	GERADE EINSCHR. F40X
55	64043	1	KULMALIITIN 90 AST	ELBOW FITTING 90 DE	VINKELKOPPLING 90 GR	WINKEL-VERSCHR. C6XS
60	74766	1	KUUSIORUUVI ZN	HEXAGONAL SCREW M8x1	SEKKANTSKRUV M8x140	SECHSKANTSCHRAUBE M8
61	72116	4	KUUSIORUUVI ZN	HEXAGONAL SCREW M 6x	SEKKANTSKRUV M 6x12	SECHSKANTSCHRAUBE M
62	73199	8	KUUSIORUUVI ZN	HEXAGONAL SCREW M6x3	SEKKANTSKRUV M6x30 D	SECHSKANTSCHRAUBE M6
63	73039	8	KUUSIORUUVI ZN	HEXAGONAL SCREW M 8	SEKKANTSKRUV M 8x16	SECHSKANTSCHRAUBE M
64	72147	9	KUUSIORUUVI ZN	HEXAGONAL SCREW M 10	SEKKANTSKRUV M 10x16	SECHSKANTSCHRAUBE M
66	72167	2	KUUSIORUUVI ZN	HEXAGONAL SCREW M12x	FINGERSKRUV M6x20 R3	SECHSKANTSCHRAUBE M1
70	72324	2	KUUSIOMUTTERI	HEXAGONAL NUT M 12	SEKKANTMUTTER M 12	SECHSKANTMUTTER M12
71	72320	5	KUUSIOMUTTERI ZN	NUT M8 NYLOC DIN 98	SEKKANTMUTTER M8 NY	SECHSKANTMUTTER M 8
73	A48492	2	KORIALUSLEVY M8X40	HEXAGONAL SCREW UNC	SEKKANTSKRUV UNC 3/8	SECHSKANTSCHRAUBE UN
74	71691	2	ALUSLEVY M12	WASHER M12 DIN 125	BRICKA M12 DIN 125	UNTERLEGSSCHEIBE M12
75	74530	12	ALUSLEVYPARI M 6	WASHER NORDLOCK NL6	BRICKA NORDLOCK NL6	UNTERLEGSSCHEIBE NORD
76	63944	6	ALUSLEVYPARI M 8	WASHER, PAIR, NORD-L	BRICKA NORD-LOCK M8,	UNTERLEGSSCHEIBE, PAA
77	71685	2	ALUSLEVY M 8	WASHER M 8 DIN 440	BRICKA M 8 DIN 440	UNTERLEGSSCHEIBE M 8
78	74531	11	ALUSLEVYPARI M10	SPACER NORDLOCK M10	BRICKA NORDLOCK M10,	UNTERLEGSSCHEIBE NORD
79	74532	2	ALUSLEVYPARI M12	WASHER NORDLOCK NL12	BRICKA NORDLOCK NL12	UNTERLEGSSCHEIBE NORD

A33932 CONTROL VALVE, COMPLETE

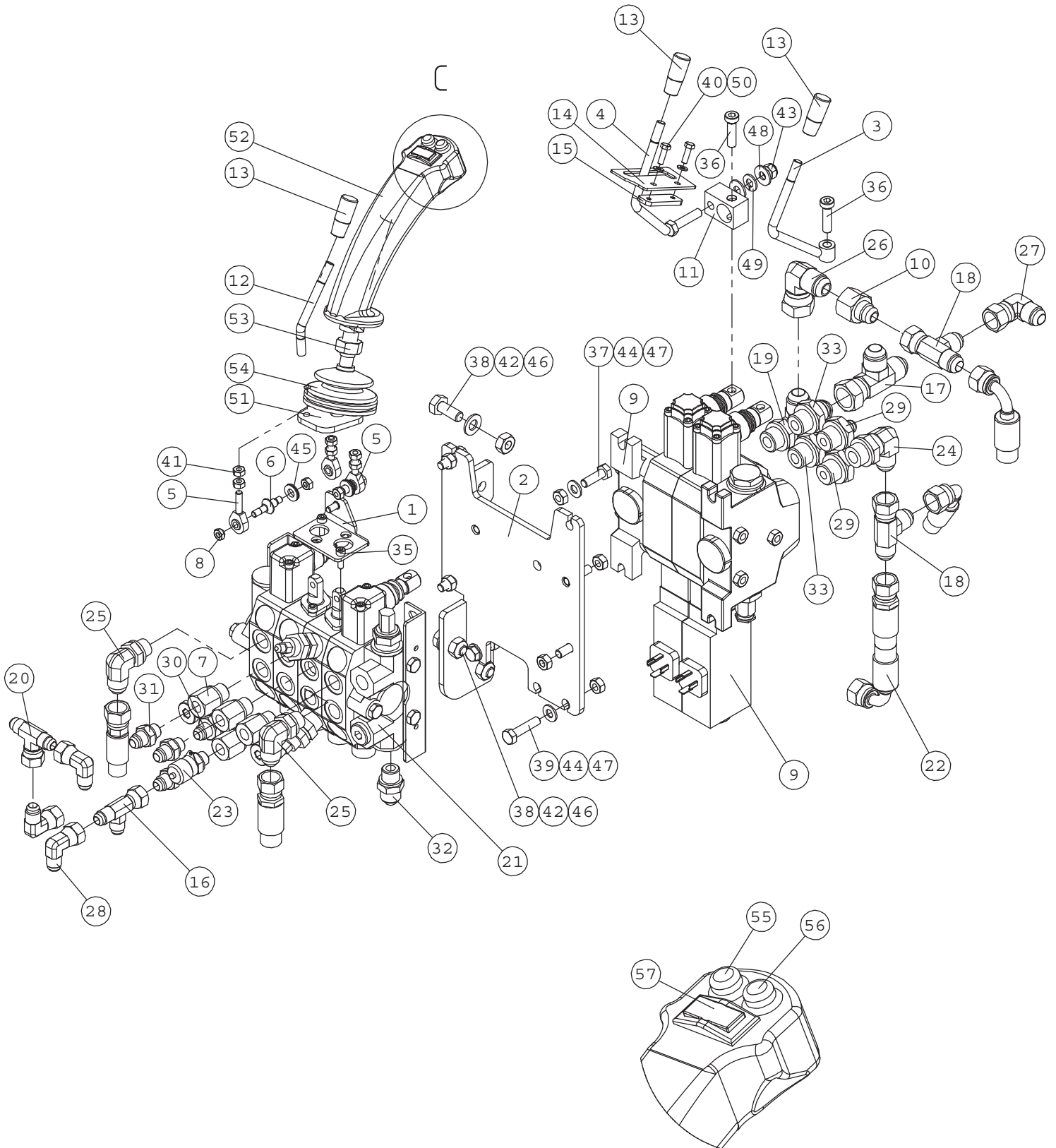

DETAIL C
SCALE 1 : 2

A33932 CONTROL VALVE, COMPLETE

NRO REF POS TEIL	OSAN NRO PART NO BESTÄLL.NR BEST.NR	KPL QTY ST ST	NIMITYS	DESCRIPTION	BENÄMNING	BEZEICHNUNG
1	A42838	1	KORVAKE KP	BRACKET, LINKAGE CON	FÄSTE, LEDLAGER, LAS	AUFNAHME, GELENKLAGE
2	A47448	1	VENTTI.KIINNITYSTASO	MOUNTING PLATE, CONT	FÄSTE, STYRVENTIL	AUFNAHMEPLATTE, STEU
3	A47727	1	ZOOM-KÄYTTÖVIPU	CONTROL LEVER, TELES	REGLAGE, TELESKOPUTS	BEDIENHEBEL, TELESKO
4	A48357	1	LISÄHYDR.VIPU KP	CONTROL LEVER, AUXIL	REGLAGE, YTTRE HYDRA	BEDIENHEBEL, ZUSATZH
5	63690	3	NIVELVARSI	ROD END BEARING AS	LÄNKHUVUD ASAHI JA	GELENKKOPF ASAHI JAM
6	A41821	2	VIVUSTON TAPPI	PIN, CONTROL LEVERS	STÄNGGÄNGS TAPP	HEBELZAPFEN
7	64324	4	SUPISTIN	REDUCER FITTING RI 3	FÖRMINSKNINGSKOPPLIN	REDUZIERVERSCHRAUBUN
8	A41822	2	VIVUSTON MUTTERI	LEVERAGE NUT M 6	MUTTER I STÄNGGÄNG	SELBSTSICHERNDE - MU
9	64928	1	SUUNTA V. HC-D3M/2	DIRECTIONAL VALVE HC	RIKTNINGSVENTIL HC-D	MAGNETVENTIL HC-D3M/
	64936		SUUNTA V. HC-D3M/2	CONTROL VALVE HC-D3M	RIKTNINGSVENTIL HC-D	STEUERGERÄT HC-D3M/2
10	64909	1	SUPISTIN	REDUCER FITTING TRTX	REDUCERINGSKOPPLING	REDUZIERVERSCHRAUBUN
11	A47725	1	RISTIKAPPALE	MOUNTING PIECE, CROS	FÄSTSTYCKE, REGLAGE	AUFNAHME TEIL, KREUZ,
12	A48252	1	VIPU	CONTROL LEVER	REGLAGE	BEDIENHEBEL
13	74761	3	NUPPI HYDR.VIPUUN	KNOB, CONTROL LEVER	KNOPP, REGLAGE	KNOPF, BEDIENHEBEL
14	A48070	1	LUKITUSHALLO	LOCKING PLATE, CONTR	LÄSPLATTA, REGLAGE	VERRIEGELUNGSKULISSE
15	A48360	1	LUKITUSPALA	LOCKING PIECE	LÄSSTYCKE	VERRIEGELUNGSTÜCK
16	64078	1	L-LIITINRUNKO	L-FITTING BODY R6XS1	L-KOPPLING RAM R6XS	L - VERSCHRAUBUNG R6
17	64303	1	L-LIITINRUNKO	L FITTING R6XS16	L KOPPLINGSHUS R6XS1	L VERSCHRAUBUNG R6XS
18	64050	2	L-LIITINRUNKO	L-FITTING BODY R6XS1	L-KOPPLINGSHUS R6	L-VERSCHRAUBUNG R6XS
19	64910	1	L-LIITINRUNKO	L FITTING R40XS16-1/	L KOPPLING R40XS16-1	L VERSCHRAUBUNG R40X
20	64070	1	T-KIERRELIITINRUNKO	T FITTING S6XS10	T-KOPPLING S6XS10	T-VERSCHRAUBUNG S6XS
21	65038	1	SUUNTAVENTTIILI HI H	CONTROL VALVE HDS 11	RIKTNINGSVENTIL HDS	STEUERGERÄT HDS 11/4
22	A47641	1	HYDR.LETKU L=1570 R2	HYDR. HOSE L=1570 R2	HYDRAULSLANG L=1570	HYDR. SCHLAUCH L=157
23	64196	1	MITTAUSPIKALIITIN	MANOMETER FITTING M1	MANOMETERKOPPLING M1	MANOMETERSCHNELLVERS
24	64045	1	KULMALIITIN 90 AST	ELBOW FITTING 90 DE	VINKELKOPPLING 90 G	WINKEL EINSCHRAUBVER
25	64068	2	KULMALIITIN 90 AST.	ELBOW FITTING 90 DEG	VINKELKOPPLING 90 GR	WINKEL EINSCHRAUBVER
26	64306	1	KULMALIITIN 90 AST	ELBOW FITTING 90 DEG	VINKELKOPPLING 90 GR	WINKEL-VERSCHR. 90 G
27	64134	1	KULMALIITIN 90 AST	ELBOW FITTING 90 DEG	VINKELKOPPLING 90 GR	WINKEL-VERSCHR. 90 G
28	64043	3	KULMALIITIN 90 AST	ELBOW FITTING 90 DE	VINKELKOPPLING 90 GR	WINKEL-VERSCHR. C6XS
29	64040	2	PERUSLIITIN	BASIC FITTING F40X	RAK KOPPLING F40XS	GERADE EINSCHR. F40X
30	64041	1	PERUSLIITIN	BASIC FITTING F40X	RAK KOPPLING F40XS	GERADE EINSCHR. F40X
31	64059	3	PERUSLIITIN	BASIC FITTING F40XS1	RAK KOPPLING F40XS10	GERADE EINSCHR. F40X
32	64042	1	PERUSLIITIN	BASIC FITTING F40	RAK KOPPLING F40X	GERADE EINSCHRAUBVER
33	64058	2	PERUSLIITIN	BASIC FITTING F40XS1	RAK KOPPLING F40XS12	GERADE EINSCHRAUBVER
34	A33332	1	SÄHKÖSARJA JOY-STICK	WIRE HARNESS JOYSTIC	LEDNINGSSATS JOYSTIC	KABELBAUM JOYSTICK 6
35	74472	2	KUUSIOKOLORUUVI	HEXAGONAL HEAD SCREW	SEXKANTHÅLSKRUV M 5x	INNEN-SECHSKANTSCHRA
36	73100	2	KUUSIOKOLORUUVI	HEXAGONAL SCREW M8x3	SEXKANTHÅLSKRUV M8x3	INNENSECHSKANT - SCH
37	72132	3	KUUSIORUUVI ZN	HEXAGONAL SCREW M8x3	SEXKANTSKRUV M8x30 D	SECHSKANTSCHRAUBE M
38	72150	3	KUUSIORUUVI ZN	HEXAGONAL SCREW M10x	SEXKANTSKRUV M10x25	SECHSKANTSCHRAUBE M1
39	73443	2	KUUSIORUUVI ZN	HEXAGONAL SCREW M8x3	SEXKANTSKRUV M8x35	SECHSKANTSCHRAUBE M8
40	72110	2	KUUSIORUUVI ZN	HEX. SCREW M5x16 DIN	SEXKANTSKRUV M5x16 D	SECHSKANTSCHRAUBE M5
41	72317	8	KUUSIOMUTTERI	HEXAGONAL NUT M6 DI	SEXKANTMUTTER M6	SECHSKANTMUTTER M 6
42	72321	3	KUUSIOMUTTERI ZN	HEXAGONAL NUT M10 D	SEXKANTMUTTER M10 DI	SECHSKANTMUTTER M10
43	72320	1	KUUSIOMUTTERI ZN	NUT M8 NYLOC DIN 98	SEXKANTMUTTER M8 NY	SECHSKANTMUTTER M 8
44	72319	9	KUUSIOMUTTERI ZN	HEXAGONAL NUT M8 DI	SEXKANTMUTTER M8 DIN	SECHSKANTMUTTER M8 D
45	63944	2	ALUSLEVYPARI M 8	WASHER, PAIR, NORD-L	BRICKA NORD-LOCK M8,	UNTERLEGSSCHEIBE, PAA
46	73121	3	ALUSLEVY M10 A10,5	WASHER M 10 DIN 12	BRICKA M 10 DIN 12	UNTERLEGSSCHEIBE M10
47	73122	5	ALUSLEVY M 8	WASHER M8 DIN 125 Z	BRICKA M8 DIN 125 Z	UNTERLEGSSCHEIBE M8 D
48	74525	2	ALUSLEVY M 8	WASHER M8 8,4x20x1,	BRICKA M8 8,4x20x1,	UNTERLEGSSCHEIBE M8
49	73962	1	ALUSLEVY M 8	WASHER M 8 DIN 127	BRICKA M 8 DIN 127	UNTERLEGSSCHEIBE M 8
50	74448	2	ALUSLEVY M 5	WASHER M5 A5,3 DIN	BRICKA M5 A5,3 DIN	UNTERLEGSSCHEIBE M5
51	47447	1	VIPU KP	BRACKET, CONTROL LEV	FÄSTE, REGLAGE, BOM	AUFNAHME, BEDIENHEBE
52	A410556		JOYSTICK KAHVA WALVO	JOYSTICK HANDLE HB00	JOYSTICK HANDTAG HB0	JOYSTICK-GRIFF HB000
	64641		JOYSTICK KAHVA WALVO	JOYSTICK VALVOIL HA0	JOYSTICK VALVOIL HA0	JOYSTICK VALVOIL HA0
53	74676		KUUSIOMUTTERI	HEXAGONAL NUT M 14x1	SEXKANTMUTTER M 14x1	SECHSKANTMUTTER M 14
54	74327		SUOJAKUMI	RUBBER COVER LEVER A	SKYDDGUMMI REGLAGE Y	SCHUTZGUMMI F12/56x4
55	65406		PAINOKYTKIN PUNAIN	PUSHBUTTON, RED, AUX	TRYCKKNAPP RÖD, JOYS	DRUCKKNOPF ROT, JOYS
56	65407		PAINOKYTKIN SININEN	PUSHBUTTON, BLUE, JO	TRYCKKNAPP BLÅ, JOYS	DRUCKKNOPF BLAU, JOY
57	65408		KEINUKYTKIN	TOGGLE SWITCH, BLACK	VIPPBRYTARE, SVART,	KIPPSCHALTER, SCHWAR

x = optional extra

A49119 ROPS FRAME WITH FOPS

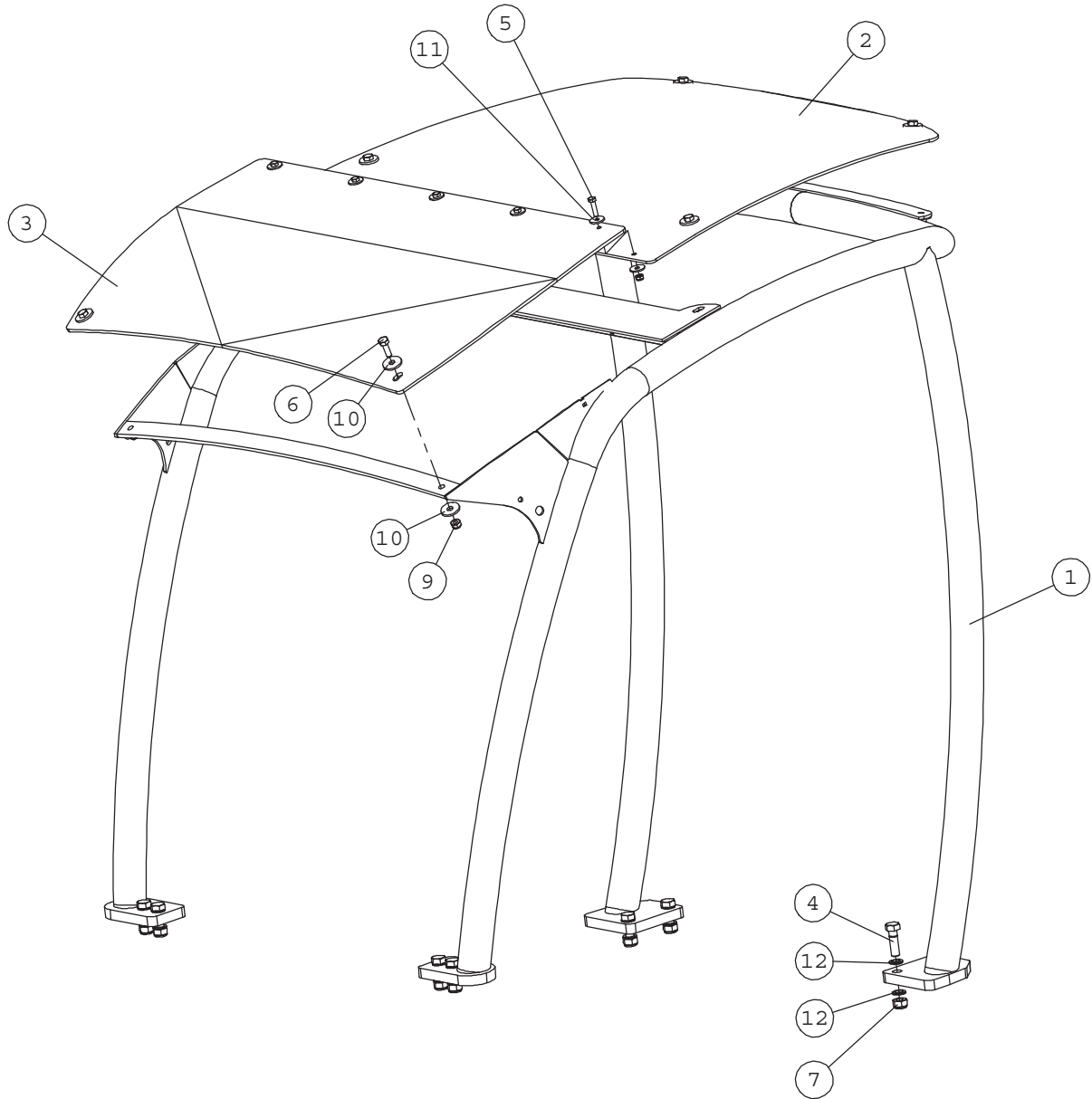

NRO REF POS TEIL	OSAN NRO PART NO BESTÄLL.NR BEST.NR	KPL QTY ST ST	NIMITYS	DESCRIPTION	BENÄMNING	BEZEICHNUNG
1	A33920	1	TURVAKAARI KORKEA	ROPS FRAME 1090 MM,	ROPS SÄKERHETSBJÄGE 1	ROPS ÜBERROLLBÜGEL 1
2	A48905	1	TURVAKAAREN FOPS LEV	FOPS CANOPY PLATE 50	FOPS TAKSKIVA 500/60	FOPS DACHBLECH 500/6
3	A48909	1	TURVAKAAREN KATTOLE	CANOPY, SHORT, POLYC	TAKSKIVA, KORT, POLY	DACHSCHEIBE, KURZ, P
4	73322	8	KUUSIORUUVI ZN	HEXAGONAL SCREW M12x	SEXXKANTSKRUV M12x40	SECHSKANTSCHRAUBE M12
5	72119	5	KUUSIORUUVI ZN	HEXAGONAL SCREW M6x2	SEXXKANTSKRUV M6x25 D	SECHSKANTSCHRAUBE M6
6	72132	6	KUUSIORUUVI ZN	HEXAGONAL SCREW M 8	SEXXKANTSKRUV M 8x2	SECHSKANTSCHRAUBE M8
7	72324	8	KUUSIOMUTTERI	HEXAGONAL NUT M 12	SEXXKANTMUTTER M 12	SECHSKANTMUTTER M12
8	72318	5	KUUSIOMUTTERI	SIXTH NUT M 6 DIN 98	SEXXKANTMUTTER M6 NY	SECHSKANTMUTTER M 6
9	72320	6	KUUSIOMUTTERI ZN	NUT M8 NYLOC DIN 98	SEXXKANTMUTTER M8 NY	SECHSKANTMUTTER M 8
10	71685	12	ALUSLEVY M 8	WASHER M 8 DIN 440	BRICKA M 8 DIN 440	UNTERLEGSCHIEBE M 8
11	71681	10	ALUSLEVY M 6	WASHER M6 DIN 440	BRICKA M 6 DIN 440	UNTERLEGSCHIEBE M 6
12	74532	16	ALUSLEVYPARI M12	WASHER NORDLOCK NL12	BRICKA NORDLOCK NL12	UNTERLEGSCHIEBE NORD

A414874 HYDRAULIC MOTOR, FRONT

Before serial number XXXXX1342

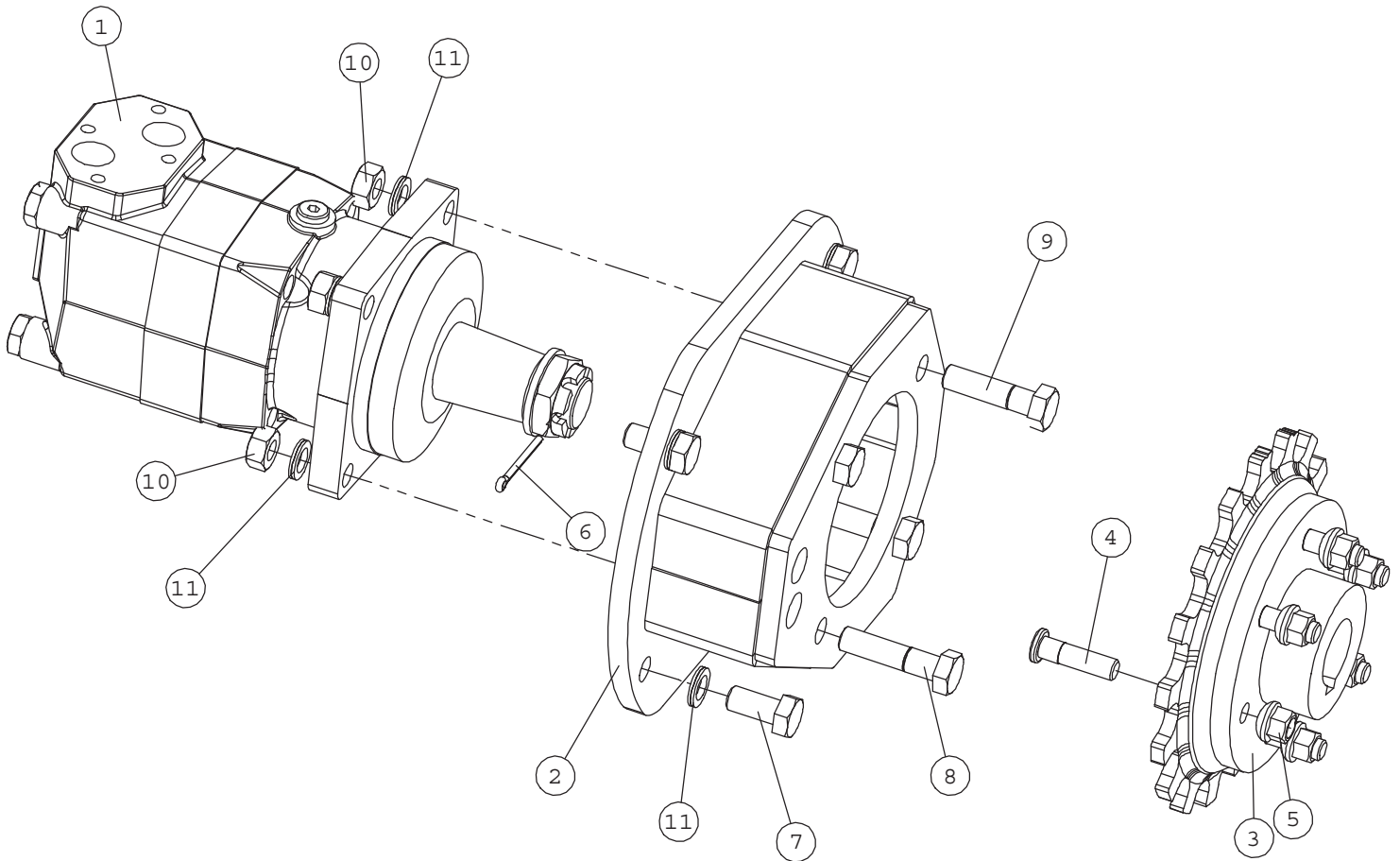

NRO REF POS TEIL	OSAN NRO PART NO BESTÄLL.NR BEST.NR	KPL QTY ST ST	NIMITYS	DESCRIPTION	BENÄMNING	BEZEICHNUNG
1	64617	1	HYDR.MOOTTORI	HYDRAULIC MOTOR OMT	HYDRAULMOTOR OMT 315	HYDROMOTOR OMT 315 1
	64541		HYDR.MOOTTORI	HYDRAULIC MOTOR OMT	HYDRAULMOTOR OMT 400	HYDROMOTOR OMT 400 1
	64698		HYDR.MOOTTORI	HYDRAULIC MOTOR OMT	HYDRAULMOTOR OMT 500	HYDRAULIKMOTOR OMT 5
	64609		TIIVISTESARJA 41 512	SEAL KIT 41 5129 700	TÄTNINGSSATS 41 5129	DICHTSATZ 41 5129 70
2	A414793	1	ADAPTERI OMT	MOUNTING BRACKET, HY	FÄSTE, HYDRAULMOTOR	AUFNAHME, HYDRAULIKM
3	A47721	1	ETUNAPA KP	WHEEL HUB, FRONT	HJULNAV, FRAM	RADNABE, VORNE
4	74794	6	PYÖRÄNPULTTI 10.9	WHEEL BOLT 10.9 M12x	HJULBULT 10.9 M12x1,	RADBOLZEN 10.9 M12x1
5	73743	6	PYÖRÄNMUTTERI M	WHEEL NUT M12x1,5	HJULMUTTER M12x1,5	RADMUTTER M12x1,5 DI
6	71837	1	SAKSISOKKA	SPLIT PIN 5x50 D	SAXSPRINT 5x50 D	SPLINT 5x50
7	74511	4	KUUSIORUUVI ZN	HEXAGONAL SCREW	SEKKANTSKRUV	SECHSKANTSCHRAUBE
8	72186	2	KUUSIORUUVI ZN	HEXAGONAL SCREW M14x	SEKKANTSKRUV M14x60	SECHSKANTSCHRAUBE M1
9	74775	2	KUUSIORUUVI ZN	HEXAGONAL SCREW M14x	SEKKANTSKRUV M14x 55	SECHSKANTSCHRAUBE M1
10	72326	4	KUUSIOMUTTERI	HEXAGONAL NUT M14 DI	SEKKANTMUTTER M14 D	SECHSKANTMUTTER M14
11	74690	10	ALUSLEVYPARI M14	WASHER NORDLOCK M14	BRICKA NORDLOCK M14	UNTERLEGSCHIBE NORD

A414876 HYDRAULIC MOTOR, FRONT

Before serial number XXXXX1342

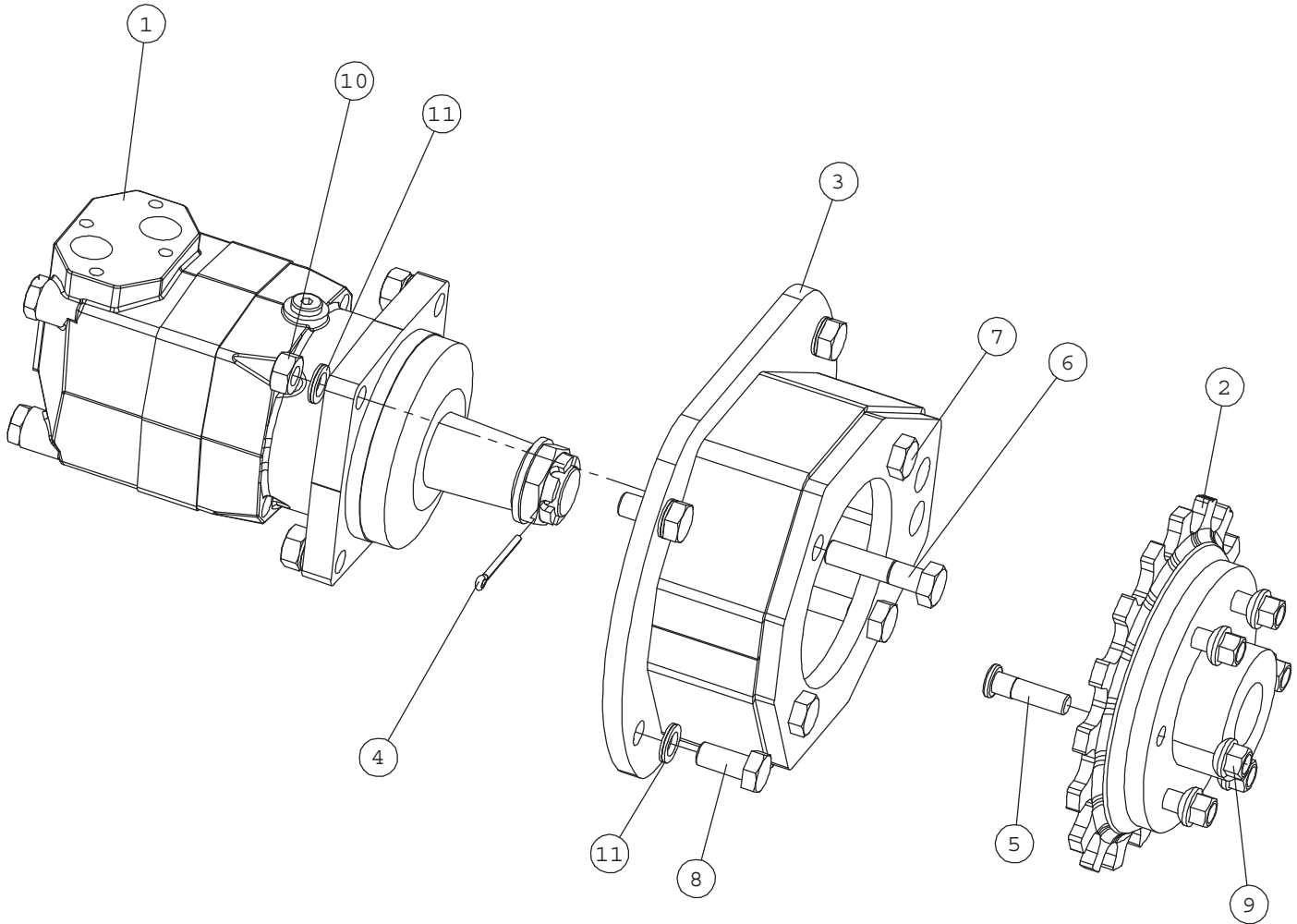

NRO REF POS TEIL	OSAN NRO PART NO BESTÄLL.NR BEST.NR	KPL QTY ST ST	NIMITYS	DESCRIPTION	BENÄMNING	BEZEICHNUNG
1	64617	1	HYDR.MOOTTORI	HYDRAULIC MOTOR OMT	HYDRAULMOTOR OMT 315	HYDROMOTOR OMT 315 1
	64541		HYDR.MOOTTORI	HYDRAULIC MOTOR OMT	HYDRAULMOTOR OMT 400	HYDROMOTOR OMT 400 1
	64698		HYDR.MOOTTORI	HYDRAULIC MOTOR OMT	HYDRAULMOTOR OMT 500	HYDRAULIKMOTOR OMT 5
	64609		TIIVISTESARJA 41 512	SEAL KIT 41 5129 700	TÄTNINGSSATS 41 5129	DICHTSATZ 41 5129 70
2	A4 7721	1	ETUNAPA KP	WHEEL HUB, FRONT	HJULNAV, FRAM	RADNABE, VORNE
3	A414 793	1	ADAPTERI OMT	MOUNTING BRACKET, HY	FÄSTE, HYDRAULMOTOR	AUFNAHME, HYDRAULIKM
4	71837	1	SAKSISOKKA	SPLIT PIN 5x50 D	SAXSPRINT 5x50 D	SPLINT 5x50
5	74 794	6	PYÖRÄNPULTTI 10.9	WHEEL BOLT 10.9 M12x	HJULBULT 10.9 M12x1,	RADBOLZEN 10.9 M12x1
6	72186	2	KUUSIORUUVI ZN	HEXAGONAL SCREW M14x	SEKKANTSKRUV M14x60	SECHSKANTSCHRAUBE M1
7	74 775	2	KUUSIORUUVI ZN	HEXAGONAL SCREW M14x	SEKKANTSKRUV M14x 55	SECHSKANTSCHRAUBE M1
8	74 511	4	KUUSIORUUVI ZN	HEXAGONAL SCREW	SEKKANTSKRUV	SECHSKANTSCHRAUBE
9	73743	6	PYÖRÄNMUTTERI M	WHEEL NUT M12x1,5	HJULMUTTER M12x1,5	RADMUTTER M12x1,5 DI
10	72326	4	KUUSIOMUTTERI	HEXAGONAL NUT M14 DI	SEKKANTMUTTER M14 D	SECHSKANTMUTTER M14
11	74 690	10	ALUSLEVYPARI M14	WASHER NORDLOCK M14	BRICKA NORDLOCK M14	UNTERLEGSCHIBE NORD

A414923 HYDRAULIC MOTOR, REAR

Before serial number XXXXX1342

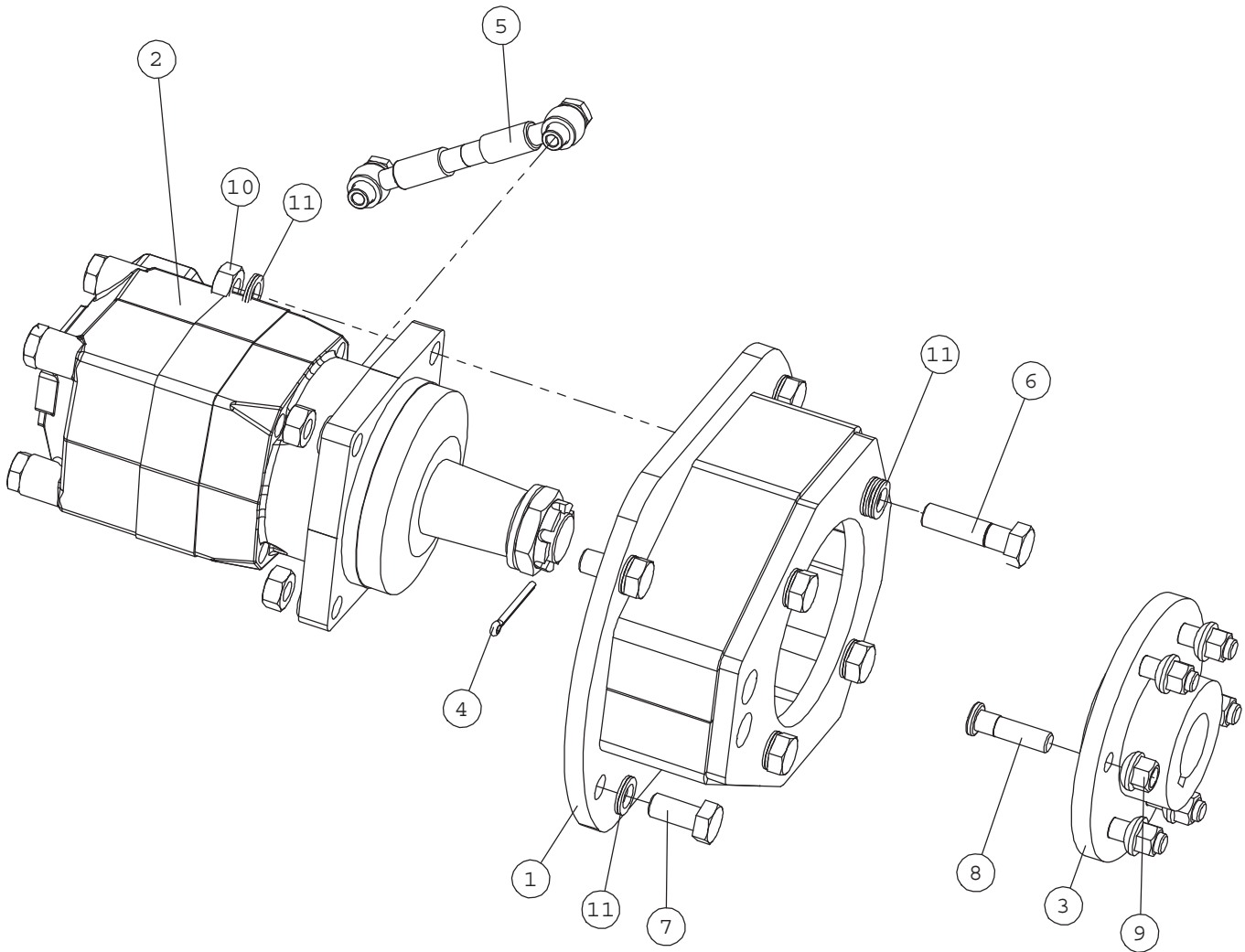

NRO REF POS TEIL	OSAN NRO PART NO BESTÄLL.NR BEST.NR	KPL QTY ST ST	NIMITYS	DESCRIPTION	BENÄMNING	BEZEICHNUNG
1	A414793	1	ADAPTERI OMT	MOUNTING BRACKET, HY	FÄSTE, HYDRAULMOTOR	AUFNAHME, HYDRAULIKM
2	64617	1	HYDR.MOOTTORI	HYDRAULIC MOTOR OMT	HYDRAULMOTOR OMT 315	HYDROMOTOR OMT 315 1
	64541		HYDR.MOOTTORI	HYDRAULIC MOTOR OMT	HYDRAULMOTOR OMT 400	HYDROMOTOR OMT 400 1
	64698		HYDR.MOOTTORI	HYDRAULIC MOTOR OMT	HYDRAULMOTOR OMT 500	HYDRAULIKMOTOR OMT 5
	64609		TIIVISTESARJA 41 512	SEAL KIT 41 5129 700	TÄTNINGSSATS 41 5129	DICHTSATZ 41 5129 70
3	A46281	1	NAPA OMT 635/630 6-P	WHEEL HUB	HJULNAV	RADNABE
4	71837	1	SAKSISOKKA	SPLIT PIN 5x50 D	SAXSPRINT 5x50 D	SPLINT 5x50
5	a47831	1	VUOTOLINJA KP , TAKA	DRAIN LINE KIT, REAR	LÄCKLEDNINGSSATS BAK	LECKÖLLEITUNGSSATZ,
6	74775	4	KUUSIORUUVI ZN	HEXAGONAL SCREW M14x	SEKKANTSKRUV M14x 55	SECHSKANTSCHRAUBE M1
7	74511	4	KUUSIORUUVI ZN	HEXAGONAL SCREW	SEKKANTSKRUV	SECHSKANTSCHRAUBE
8	74794	6	PYÖRÄNPULTTI 10.9	WHEEL BOLT 10.9 M12x	HJULBULT 10.9 M12x1,	RADBOLZEN 10.9 M12x1
9	73743	6	PYÖRÄNMUTTERI M	WHEEL NUT M12x1,5	HJULMUTTER M12x1,5	RADMUTTER M12x1,5 DI
10	72326	4	KUUSIOMUTTERI	HEXAGONAL NUT M14 DI	SEKKANTMUTTER M14 D	SECHSKANTMUTTER M14
11	74690	14	ALUSLEVYPARI M14	WASHER NORDLOCK M14	BRICKA NORDLOCK M14	UNTERLEGSCHIBE NORD

A34531 HYDR. HOSES, DRIVE O-LOK
Serial numbers xxxxx1006-XXXXX1341

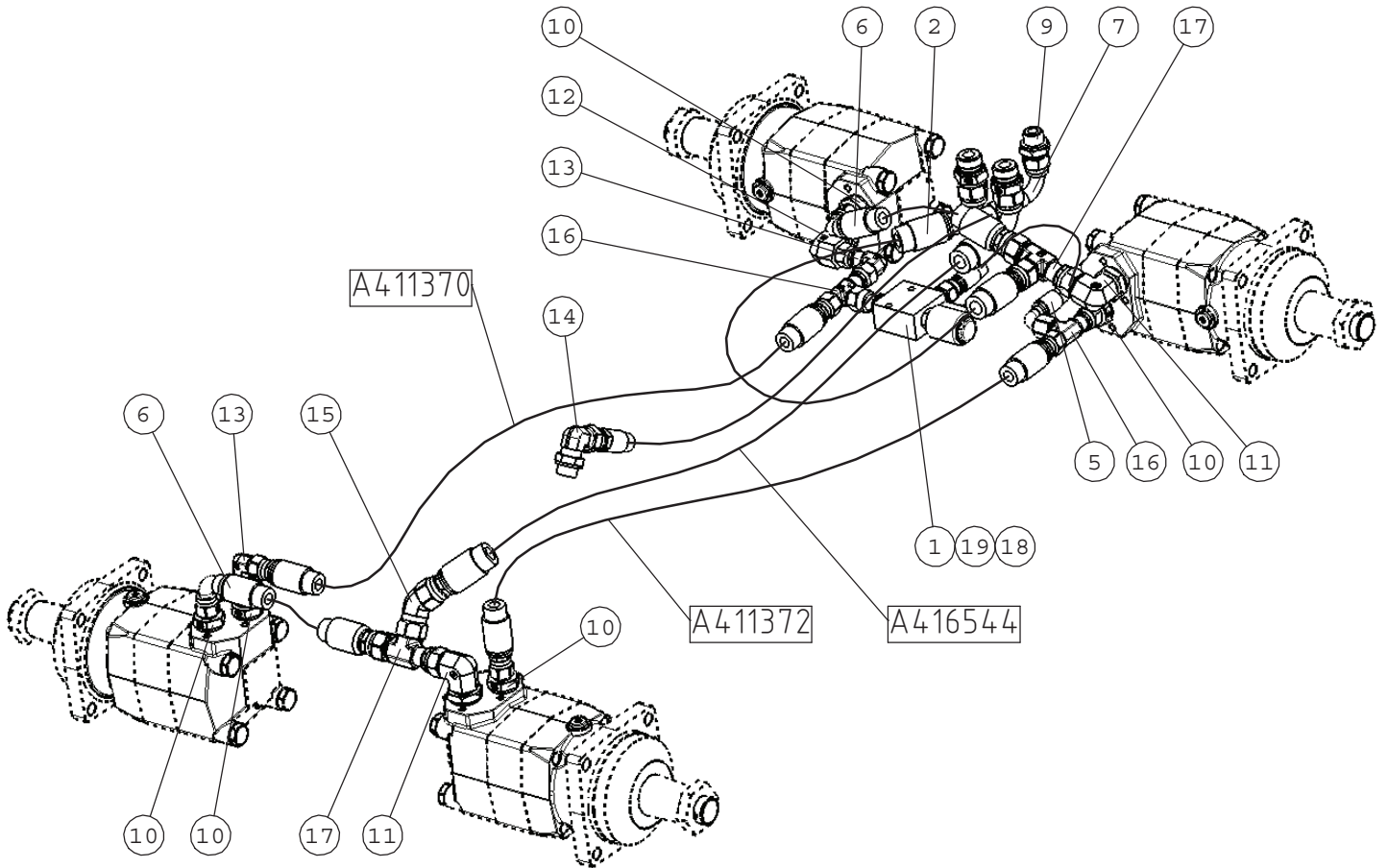

⑥

Drive motor type/size	Part number /length
OMT 315	A411374/285
OMT 400	A411459/265
OMT 500	A411375/235

A34531 HYDR. HOSES, DRIVE O-LOK
Serial numbers xxxxx1006-XXXXX1341

NRO REF POS TEIL	OSAN NRO PART NO BESTÄLL.NR BEST.NR	KPL QTY ST ST	NIMITYS	DESCRIPTION	BENÄMNING	BEZEICHNUNG
1	64676	1	SOLENOIDIVENTTIILI	SOLENOID VALVE WK08W	MAGNETVENTIL WK08W-0	MAGNETVENTIL WK08W-0
2	A411344	1	HYDR.LETKU L=800	HYDR. HOSE L=800 O-L	HYDRAULSLANG L=800 O	HYDR. SCHLAUCH L=800
3	A411370	1	HYDR.LETKU L=1400	HYDR. HOSE L=1400 O-L	HYDRAULSLANG L=1400 O	HYDR. SCHLAUCH L=1400
4	A411372	1	HYDR.LETKU L=1350	HYDR. HOSE L=1350 O-L	HYDRAULSLANG L=1350 O	HYDR. SCHLAUCH L=1350
5	A411373	1	HYDR.LETKU L=500	HYDR. HOSE L=500 O-L	HYDRAULSLANG L=500 O	HYDR. SCHLAUCH L=500
6	A411374	2	HYDR.LETKU L=285	HYDR. HOSE L=285 O-L	HYDRAULSLANG L=285 O	HYDR. SCHLAUCH L=285
7	A415903	1	HYDR. LETKU L=850	HYDR. HOSE L=850	HYDRAULSLANG L=850	HYDR. SCHLAUCH L=85
8	A416544	1	HYDR.LETKU L=1300	HYDR. HOSE L=1300	HYDRAULSLANG L=1300	HYDR. SCHLAUCH L=13
9	65060	1	PERUSLIITIN	BASIC FITTING F40XS1	RAK KOPPLING F40XS16	GERADE EINSCHRAUBVER
10	65311	5	PERUSLIITIN	BASIC FITTING	RAK KOPPLING	GERADE EINSCHRAUBVER
11	65293	2	KULMALIITIN 90 AST	ELBOW FITTING 90DEGR	VINKELKOPPLING 90GRA	WINKEL-VERSCHR. 90GR
12	65291	1	KULMALIITIN 90 AST	ELBOW FITTING 90DEGR	VINKELKOPPLING 90GR	WINKEL-VERSCHR. 90GR
13	65300	2	KULMALIITIN 90 AST	ELBOW FITTING 90DEGR	VINKELKOPPLING 90GRA	WINKEL-VERSCHR. 90GR
14	65059	1	KULMALIITIN 90 AST.	ELBOW FITTING 90DEGR	VINKELKOPPLING 90 GR	WINKEL-VERSCHRAUBUNG
15	65580	1	KULMALIITIN 45 AST.	ELBOW FITTING 45 DEG	VINKELKOPPLING 45 GR	WINKEL-VERSCHR. 45 G
16	65337	2	L-KIERRELIITINRUNKO	L FITTING 8R6MLOS	L KOPPLING 8R6MLOS	L VERSCHRAUBUNG 8R6M
17	65338	2	L-KIERRELIITINRUNKO	L FITTING 10R6MLOS	L KOPPLING 10R6MLOS	L VERSCHRAUBUNG 10R6
18	65312	1	PERUSLIITIN	BASIC FITTING 8F4.2ED	RAK KOPPLING 8F4.2EDM	GERADE EINSCHR. VERS
19	65324	1	YHDYSNIPPA	CONNECTOR NIPPLE 8F	FÖRBINDINGSNIPPEL 8	VERBINDUNGSNIPPEL 8F

A35527 HYDRAULIC HOSES, POCLAIN MOTORS
From serial number XXXXX1342

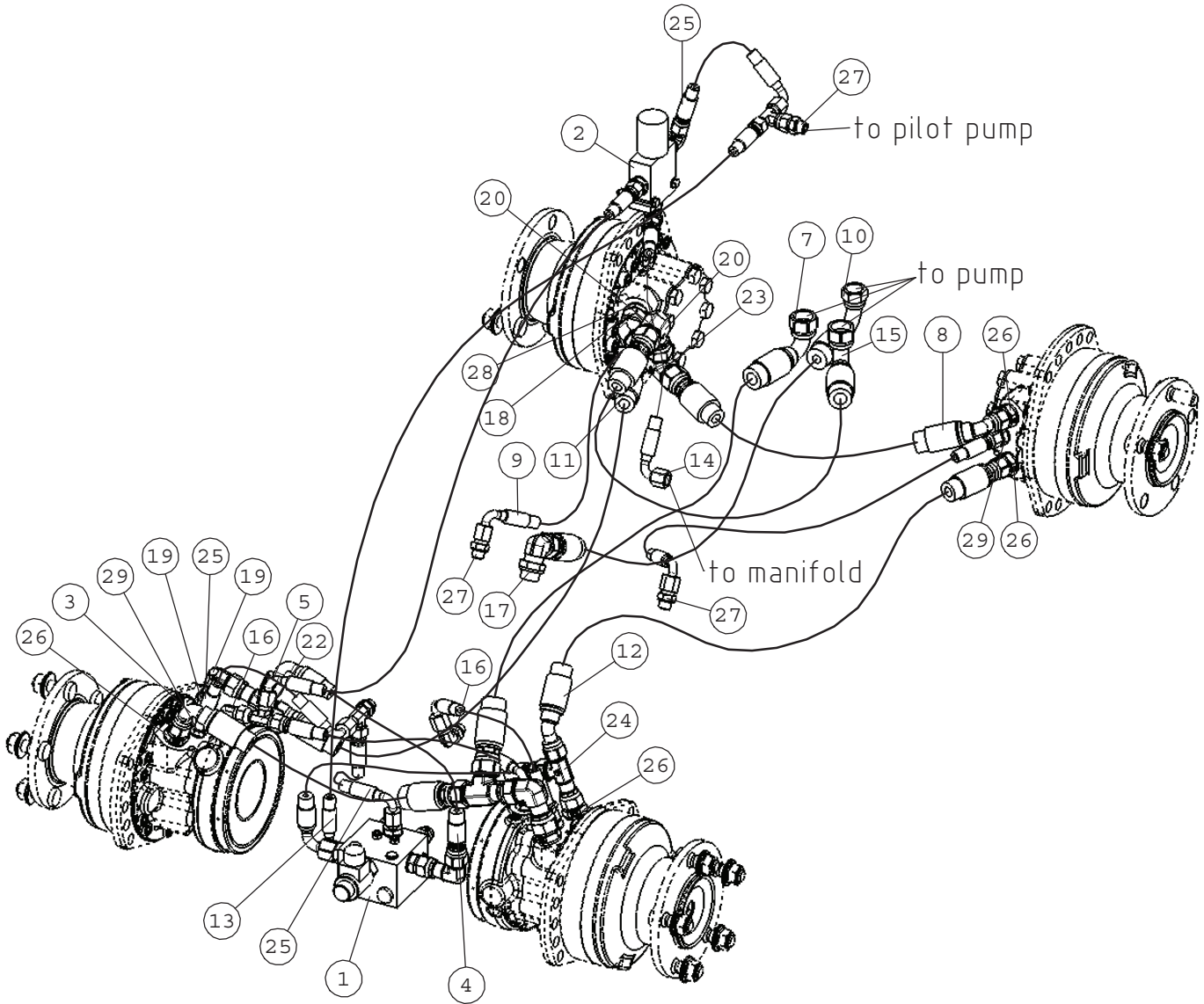

A35527 HYDRAULIC HOSES, POCLAIN MOTORS

From serial number XXXXX1342

NRO REF POS TEIL	OSAN NRO PART NO BESTÄLL.NR BEST.NR	KPL QTY ST ST	NIMITYS	DESCRIPTION	BENÄMNING	BEZEICHNUNG
1	A414957	1	A JONVAP.VENTTIILI KP	DRIVE RELEASE VALVE	FRIHJULKOPPLINGSVENT	ELEKTR. AUSGLEICHSPE
2	A414978	1	JARRUVENTTIILI KP	SOLENOID VALVE, BRAK	BROMSVENTIL, 600 SER	MAGNETVENTIL, ELEKTR
3	A415105	1	HYDR.LETKU L=400	HYDR. HOSE L=400	HYDRAULSLANG L=400	HYDR. SCHLAUCH L=40
4	A415114	2	HYDR.LETKU L=440	HYDR. HOSE L=440	HYDRAULSLANG L=440	HYDR. SCHLAUCH L=440
5	A410092	1	HYDR.LETKU L=1550	HYDR. HOSE L=1550	HYDRAULSLANG L=1550	HYDR. SCHLAUCH L=155
25	A415115	4	HYDR.LETKU L=240	HYDR. HOSE L=240	HYDRAULSLANG L=240	HYDR. SCHLAUCH L=24
7	A415118	1	HYDR.LETKU L=1300	HYDR. HOSE L=1300	HYDRAULSLANG L=130	HYDR. SCHLAUCH L=1
8	A415119	1	HYDR.LETKU L=450	HYDR. HOSE L=450	HYDRAULSLANG L=45	HYDR. SCHLAUCH L=4
9	A415120	2	HYDR.LETKU L=750	HYDR. HOSE L=750	HYDRAULSLANG L=750	HYDR. SCHLAUCH L=75
10	A415411	1	HYDR.LETKU L=900	HYDR. HOSE L=900	HYDRAULSLANG L=900	HYDR. SCHLAUCH L=900
11	a416801	1	HYDR.LETKU L=1550	HYDR. HOSE L=1550	HYDRAULSLANG L=155	HYDR. SCHLAUCH L=
12	a416802	1	HYDR.LETKU L=1280	HYDR. HOSE L=1280	HYDRAULSLANG L=12	HYDR. SCHLAUCH L=1
13	a415362	1	HYDR.LETKU L=1650	HYDR. HOSE L=1650	HYDRAULSLANG L=1650	HYDR. SCHLAUCH L=16
14	a410017	1	HYDR.LETKU L=400	HYDR. HOSE L=400	HYDRAULSLANG L=400	HYDR. SCHLAUCH L=400
15	A411344	1	HYDR.LETKU L=800	HYDR. HOSE L=800 O-L	HYDRAULSLANG L=800 O	HYDR. SCHLAUCH L=800
16	64087	2	KULMALIITIN 90 AST.	ELBOW FITTING 90 DEG	VINKELKOPPLING 90 GR	WINKEL-VERSCHR. C40X
17	65059	1	KULMALIITIN 90 AST.	ELBOW FITTING 90DEGR	VINKELKOPPLING 90 GR	WINKEL-VERSCHRAUBUNG
18	65580	1	KULMALIITIN 45 AST.	ELBOW FITTING 45 DEG	VINKELKOPPLING 45 GR	WINKEL-VERSCHR. 45 G
19	65300	1	KULMALIITIN 90 AST	ELBOW FITTING 90DEGR	VINKELKOPPLING 90GRA	WINKEL-VERSCHR. 90GR
20	65301	2	KULMALIITIN 90 AST	ELBOW FITTING 90 DGE	VINKELKOPPLING 90 GR	WINKEL-VERSCHRAUBUNG
21	64070	1	T-KIERRELIITINRUNKO	T FITTING S6XS10	T-KOPPLING S6XS10	T-VERSCHRAUBUNG S6XS
22	64078	1	L-LIITINRUNKO	L-FITTING BODY R6XS1	L-KOPPLING RAM R6XS	L - VERSCHRAUBUNG R6
23	65338	2	L-KIERRELIITINRUNKO	L FITTING 10R6MLOS	L KOPPLING 10R6MLOS	L VERSCHRAUBUNG 10R6
24	65337	2	L-KIERRELIITINRUNKO	L FITTING 8R6MLOS	L KOPPLING 8R6MLOS	L VERSCHRAUBUNG 8R6M
25	65584	1	L-LIITINRUNKO	L FITTING R40	L-KOPPLING	L- VERSCHRAUBUNG
26	65310	6	PERUSLIITIN	BASIC FITTING 8-8F42	RAK KOPPLING 8-8F42E	GERADE EINSCHR. VERS
27	64059	4	PERUSLIITIN	BASIC FITTING F40XS1	RAK KOPPLING F40XS10	GERADE EINSCHR. F40X
28	65372	2	PERUSLIITIN	BASIC FITTING 10F	RAK KOPPLING 10F	GERADE EINSCHR. VERS
29	64041	4	PERUSLIITIN	BASIC FITTING F40X	RAK KOPPLING F40XS	GERADE EINSCHR. F40X

A49058 DRIVE PEDAL

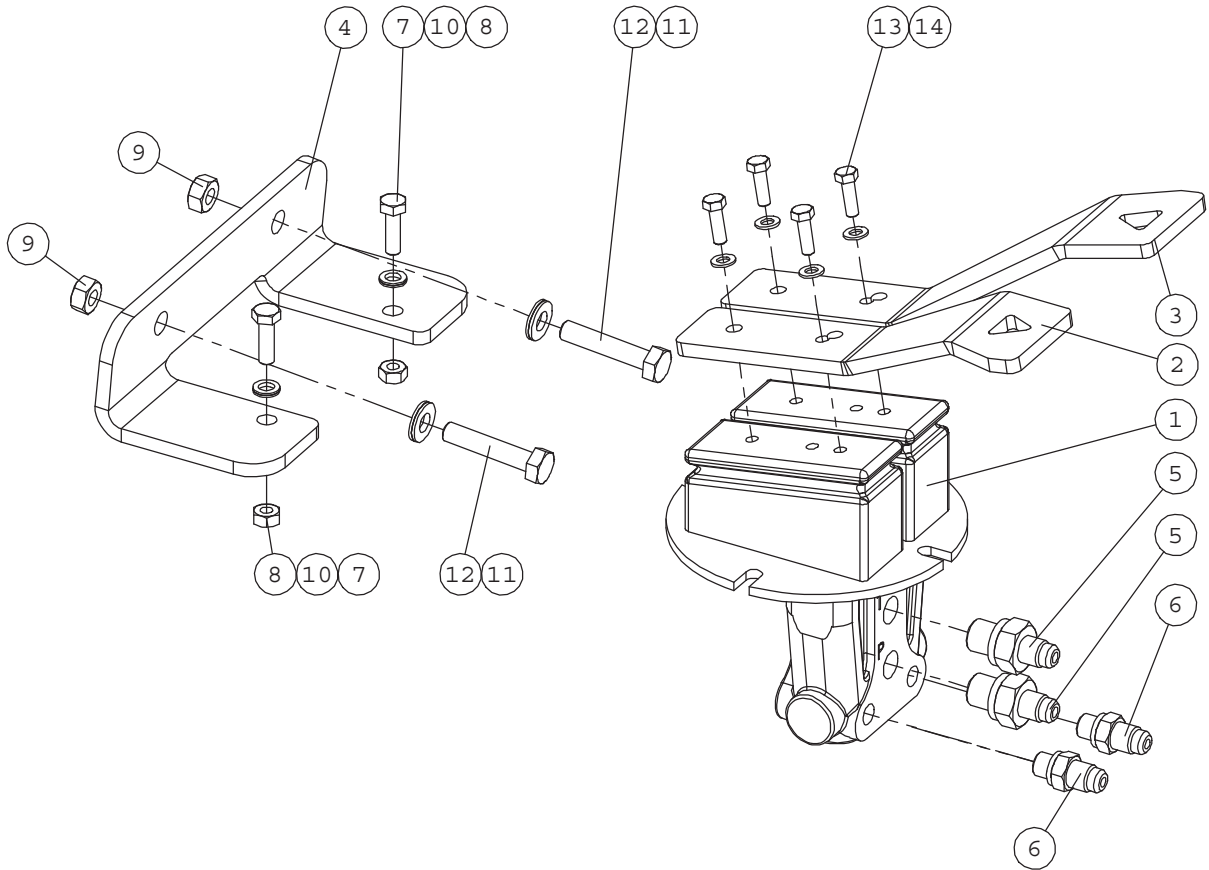

A49058 DRIVE PEDAL

NRO REF POS TEIL	OSAN NRO PART NO BESTÄLL.NR BEST.NR	KPL QTY ST ST	NIMITYS	DESCRIPTION	BENÄMNING	BEZEICHNUNG
1	64922	1	HYDR.POLJIN BONDIOLI	HYDR. PEDAL BONDIOLI	HYDR. PEDAL BONDIOLI	HYDR. PEDAL BONDIOLI
2	A47550	1	AJOPOLJIN , VASEN	DRIVE PEDAL, LEFT	KÖRPEDAL, VÄNSTER	FAHRPEDAL, LINKS
3	A47551	1	AJOPOLJIN , OIKEA	DRIVE PEDAL, RIGHT	KÖRPEDAL, HÖGER	FAHRPEDAL, RECHTS
4	A47247	1	AJOPOLKIMENKANNAKE	BRACKET, DRIVE PEDAL	FÄSTE, KÖRPEDAL	AUFNAHME, FAHRPEDAL
5	64678	2	PERUSLIITIN	BASIC FITTING F40XS6	RAK KÖPPLING F40XS6-	GERADE EINSCHRAUBVER
6	64793	2	PERUSLIITIN	BASIC FITTING F40XS6	RAK KÖPPLING F40XS6-	GERADE EINSCHRAUBVER
7	72118	2	KUUSIORUUVI ZN	HEX.HD.SCREW M6x20 D	SECKANTSKRUV M6x20 D	SECHSKANTSCHRAUBE M
8	72317	3	KUUSIOMUTTERI	HEXAGONAL NUT M6 DI	SECKANTMUTTER M6	SECHSKANTMUTTER M 6
9	72319	2	KUUSIOMUTTERI ZN	HEXAGONAL NUT M8 DI	SECKANTMUTTER M8 DIN	SECHSKANTMUTTER M8 D
10	74530	2	ALUSLEVYPARI M 6	WASHER NORDLOCK NL6	BRICKA NORDLOCK NL6	UNTERLEGSCHEIBE NORD
11	63944	2	ALUSLEVYPARI M 8	WASHER, PAIR, NORD-L	BRICKA NORD-LOCK M8,	UNTERLEGSCHEIBE, PAA
12	73222	2	KUUSIORUUVI ZN	HEXAGONAL SCREW M8x4	SECKANTSKRUV M8x40 D	SECHSKANTSCHRAUBE M8
13	72110	4	KUUSIORUUVI ZN	HEX. SCREW M5x16 DIN	SECKANTSKRUV M5x16 D	SECHSKANTSCHRAUBE M5
14	74448	4	ALUSLEVY M 5	WASHER M5 A5,3 DIN	BRICKA M5 A5,3 DIN	UNTERLEGSCHEIBE M5

A49161 HYDR. HOSES DRIVE PEDAL

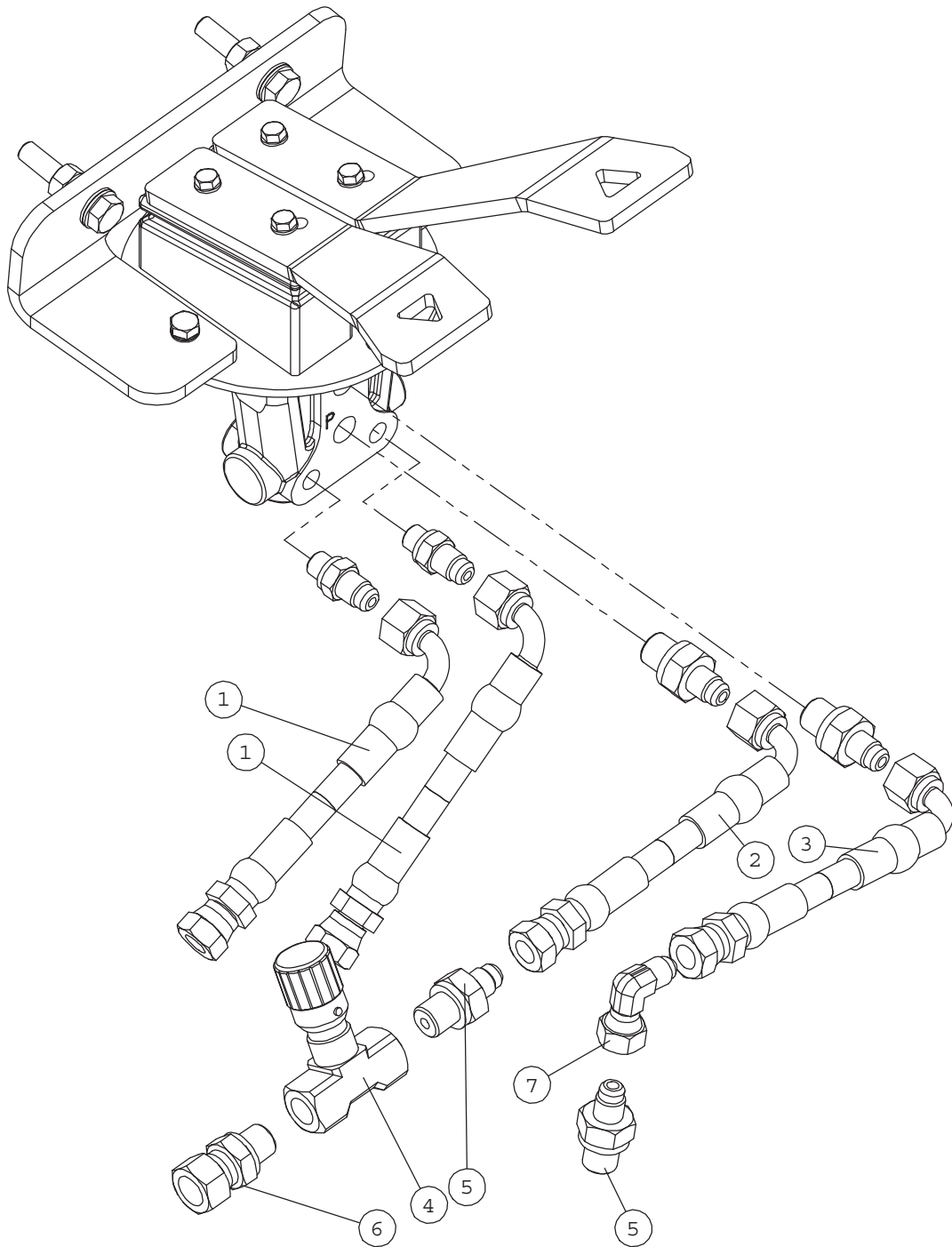

A49161 HYDR. HOSES DRIVE PEDAL

NRO REF POS TEIL	OSAN NRO PART NO BESTÄLL.NR BEST.NR	KPL QTY ST ST	NIMITYS	DESCRIPTION	BENÄMNING	BEZEICHNUNG
1	A47642	2	HYDR.LETKU L=1020 1L	HYDR. HOSE L=1020 TY	HYDRAULSLANG L=1020	HYDR. SCHLAUCH L=102
2	A47644	1	HYDR.LETKU L=960	HYDR. HOSE L=960 TYP	HYDRAULSLANG L=960 T	HYDR. SCHLAUCH L=960
3	A47643	1	HYDR.LETKU L=430 1L	HYDR. HOSE L=430 TYP	HYDRAULSLANG L=430 T	HYDR. SCHLAUCH L=430
4	63879	1	VASTUSVENTTIILI	CHECK VALVE 9N400S R	RESISTANSVENTIL 9N40	SPERRVENTIL 9N400S R
5	64678	2	PERUSLIITIN	BASIC FITTING F40XS6	RAK KÖPPLING F40XS6-	GERADE EINSCHRAUBVER
6	64060	1	YHDYSNIPPA	CONNECTOR NIPPLE F64	ÖVERGÅNGSNIPPEL F64X	VERBINDUNGSNIPPEL F6
7	64308	1	KULMALIITIN 90 AST	ELBOW FITTING 90 DEG	VINKELKÖPPLING 90 GR	WINKELVERSCHRAUBUNG

A48998 STEERING COLUMN

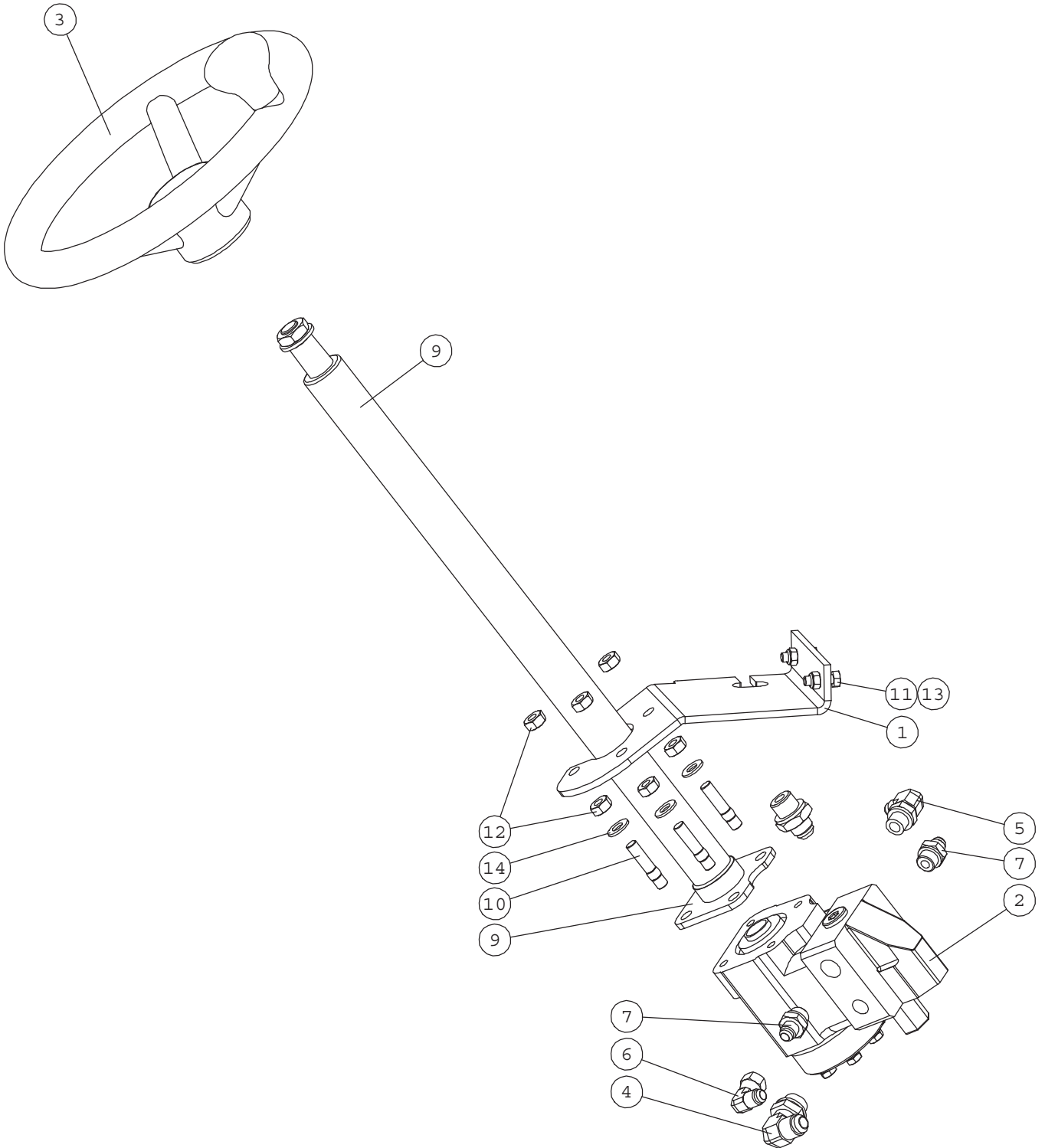

A48998 STEERING COLUMN

NRO REF POS TEIL	OSAN NRO PART NO BESTÄLL.NR BEST.NR	KPL QTY ST ST	NIMITYS	DESCRIPTION	BENÄMNING	BEZEICHNUNG
1	A47108	1	ORBITROL-KANNAKE	BRACKET, ORBITROL, 6	FÄSTE, ORBITROL, 600	AUFNAHME, ORBITROL,
2	64178	1	OHJAUSYKSIKKÖ M+S HK	CONTROL BLOCK M+S HK	STYRAGGREGAT M+S HKU	LENKAGGREGAT M+S HKU
	64611		TIIVISTESARJA 41 513	SEAL KIT 41 5137 013	TÄTNINGSSATS 41 5137	DICHTSATZ 41 5137 01
3	65076	1	OHJAUSPYÖRÄ COBO F32	STEERING WHEEL "AVAN	STEERING WHEEL "AVAN	LENKRAD "AVANT" F320
	65131		OHJAUSPYÖRÄN KESKIOLEV	CENTER CAP, STEERING	MITTPLATTA, RATT	DECKEL, LENKRAD
	65576		OHJAUSPYÖRÄN NUPPI	KNOB, STEERING WHEEL	RATTKULA, COBO	LENKRADKNOPF, COBO
4	64045	1	KULMALIITIN 90 AST	ELBOW FITTING 90 DE	VINKELKOPPLING 90 G	WINKEL EINSCHRAUBVER
5	64044	1	KULMALIITIN 90 AST	ELBOW FITTING 90 DE	VINKELKOPPLING 90 G	WINKEL EINSCHRAUBVER
6	64043	1	KULMALIITIN 90 AST	ELBOW FITTING 90 DE	VINKELKOPPLING 90 G	WINKEL EINSCHRAUBVER
7	64041	2	PERUSLIITIN	BASIC FITTING F40X	RAK KOPPLING F40XS	GERADE EINSCHRAUBVER
8	64058	1	PERUSLIITIN	BASIC FITTING F40XS1	RAK KOPPLING F40XS12	GERADE EINSCHRAUBVER
9	64780	1	OHJAUSVARSI	STEERING WHEEL ROD M	STYRPELARE M+S KK600	LENKAUFSATZ M+S KK60
10	74587	4	VAARNARUUVI	STUD M10x 35 DIN 939	PINNSKRUV M10 x35 DI	STIFTSCHRAUBE M10x 3
11	72132	2	KUUSIORUUVI ZN	HEXAGONAL SCREW M 8	SEXKANTSKRUV M 8x2	SECHSKANTSCHRAUBE M8
12	72321	8	KUUSIOMUTTERI ZN	HEXAGONAL NUT M10 D	SEXKANTMUTTER M10 DI	SECHSKANTMUTTER M10
13	72320	2	KUUSIOMUTTERI ZN	NUT M8 NYLOC DIN 98	SEXKANTMUTTER M8 NY	SECHSKANTMUTTER M 8
14	73121	4	ALUSLEVY M10 A10,5	WASHER M 10 DIN 12	BRICKA M 10 DIN 12	UNTERLEGSCHIEBE M10

A33930 HYDR. HOSES, STEERING

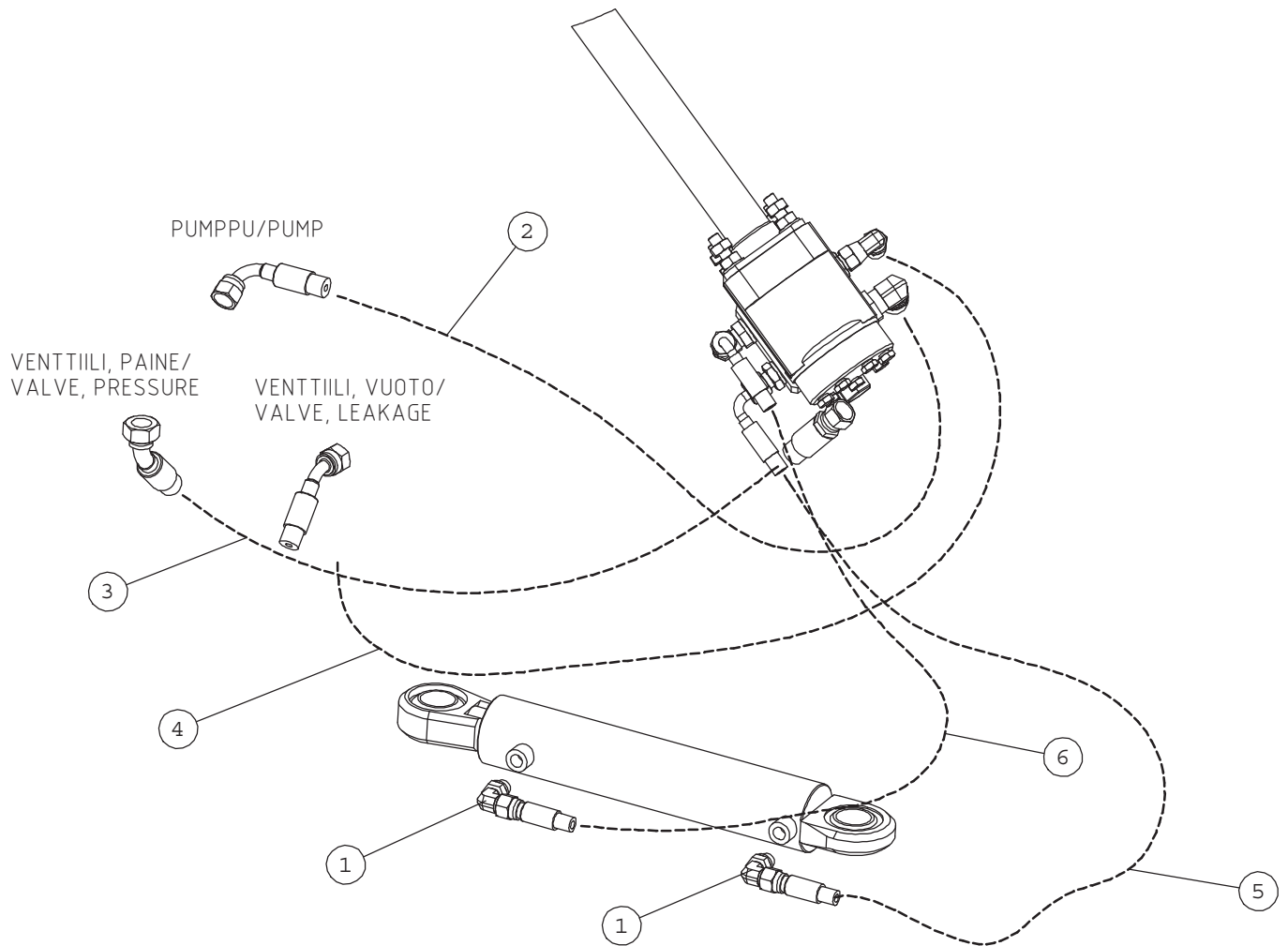

A33930 HYDR. HOSES, STEERING

NRO REF POS TEIL	OSAN NRO PART NO BESTÄLL.NR BEST.NR	KPL QTY ST ST	NIMITYS	DESCRIPTION	BENÄMNING	BEZEICHNUNG
1	64087	2	KULMALIITIN 90 AST.	ELBOW FITTING 90 DEG	VINKELKOPPLING 90 GR	WINKEL EINSCHRAUBVER
2	A48210	1	HYDR.LETKU L=1110 2L	HYDR. HOSE L=1110	HYDRAULSLANG L=1110	HYDR. SCHLAUCH L=111
3	A47634	1	HYDR.LETKU L=1400 2L	HYDR. HOSE L=1400 2L	HYDRAULSLANG L=1400	HYDR. SCHLAUCH L=140
4	A47631	1	HYDR.LETKU L=710 R1A	HYDR. HOSE L=710 R1A	HYDRAULSLANG L=710 R	HYDR. SCHLAUCH L=710
5	A47632	1	HYDR.LETKU L=960 R1A	HYDR. HOSE L=960 R1A	HYDRAULSLANG L=960 R	HYDR. SCHLAUCH L=960
6	A410126	1	HYDR.LETKU L=1550	HYDR. HOSE L=1550	HYDRAULSLANG L=1550	HYDR. SCHLAUCH L=155

A413893 HYDRAULIC OIL COOLER

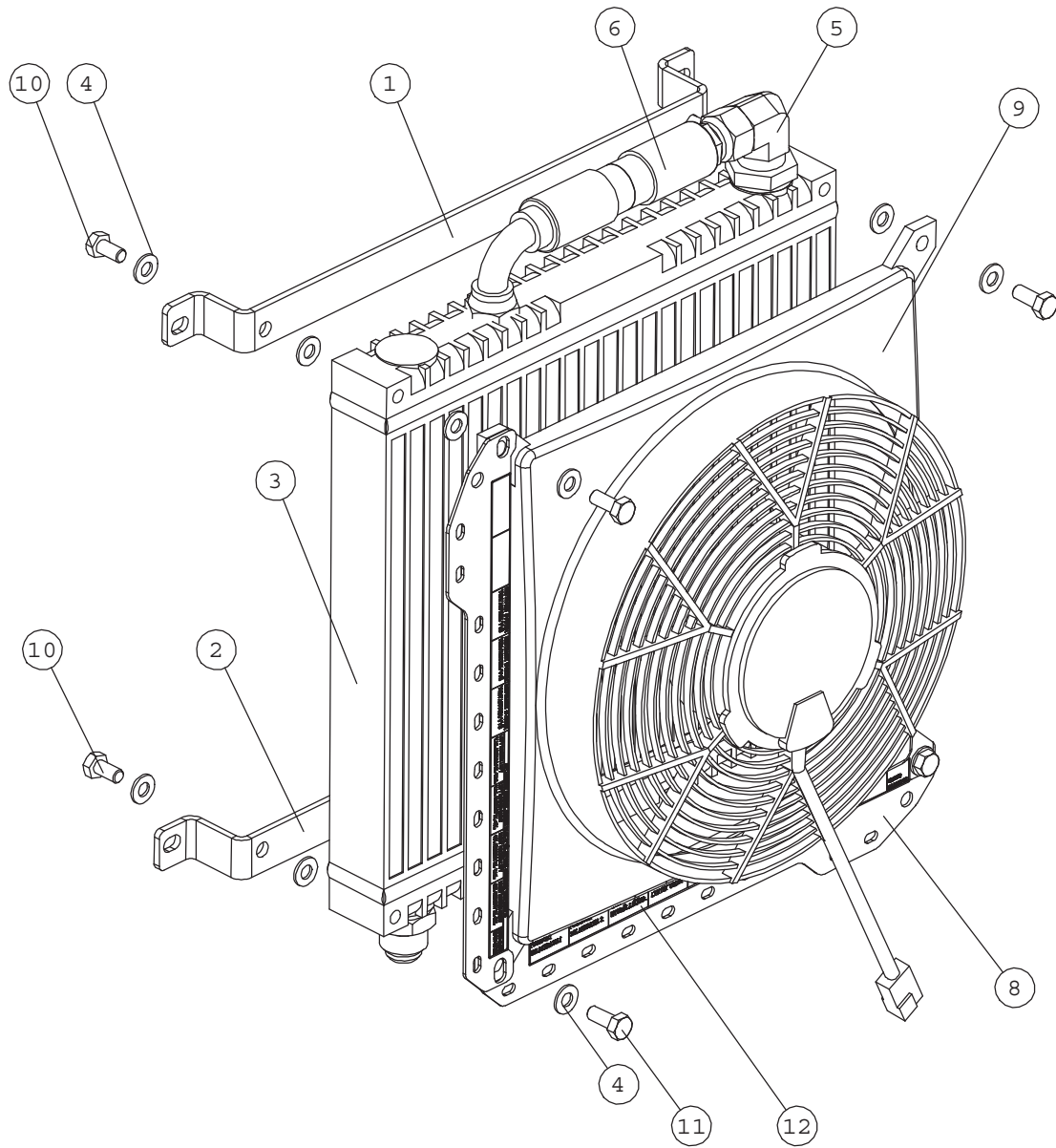

A413893 HYDRAULIC OIL COOLER

NRO REF POS TEIL	OSAN NRO PART NO BESTÄLL.NR BEST.NR	KPL QTY ST ST	NIMITYS	DESCRIPTION	BENÄMNING	BEZEICHNUNG
1	A47769	1	KIINNITYSPANTA	BRACKET, OIL COOLER,	FÄSTE, OLJEKYLARE, Ö	AUFNAHME, ÖLKÜHLER,
2	A47768	1	KIINNITYSPANTA	BRACKET, OIL COOLER,	FÄSTE, OLJEKYLARE, L	AUFNAHME, ÖLKÜHLER,
3	64934	1	ÖLJYNJÄÄHDYTINKENNO	OIL COOLER CELL ASA	OLJEKYLARECELL ASA 3	ÖLKÜHLER ASA 350x350
4	73122	14	ALUSLEVY M 8	WASHER M8 A8	BRICKA M8 A8,	UNTERLEGSSCHEIBE M8
5	64693	1	KULMALIITIN 90 AST.	ELBOW FITTING 90 DEG	VINKELKOPPLING 90 GR	WINKELVERSCHR. 90 GR
6	A47682	1	HYDR.LETKU L=290 1LW	HYDR. HOSE L=280 1LW	HYDRAULSLANG L=280 1	HYDR. SCHLAUCH L=280
7	64099	1	PERUSLIITIN	BASIC FITTING F40XS1	RAK KOPPLING F40XS18	GERADE EINSCHRAUBVER
8	a412927	1	RELEKISKO	RELAY MOUNTING RAIL	MONTERINGSSKENA, REL	RELAISSCHIENE
9	65568	1	JÄÄHDYTYSPUHALLIN C	FAN, HYDRAULIC OIL C	FLÄKT, HYDRAULOLJEKY	GEBLÄSE, HYDRAULIKÖL
10	73039	4	KUUSIORUUVI ZN	HEXAGONAL SCREW M 8	SEKANTSKRUV M 8x16	SECHSKANTSCHRAUBE M
11	72130	4	KUUSIORUUVI ZN	HEXAGONAL SCREW M8x2	SEKANTSKRUV M8x20 D	SECHSKANTSCHRAUBE M
12	A413994	1	TARRA	DECAL, RELAYS	DEKAL, RELÄER	AUFKLEBER, RELAIS

A35461 PARKING BRAKE, ASSEMBLY
Before serial number XXXXX1342

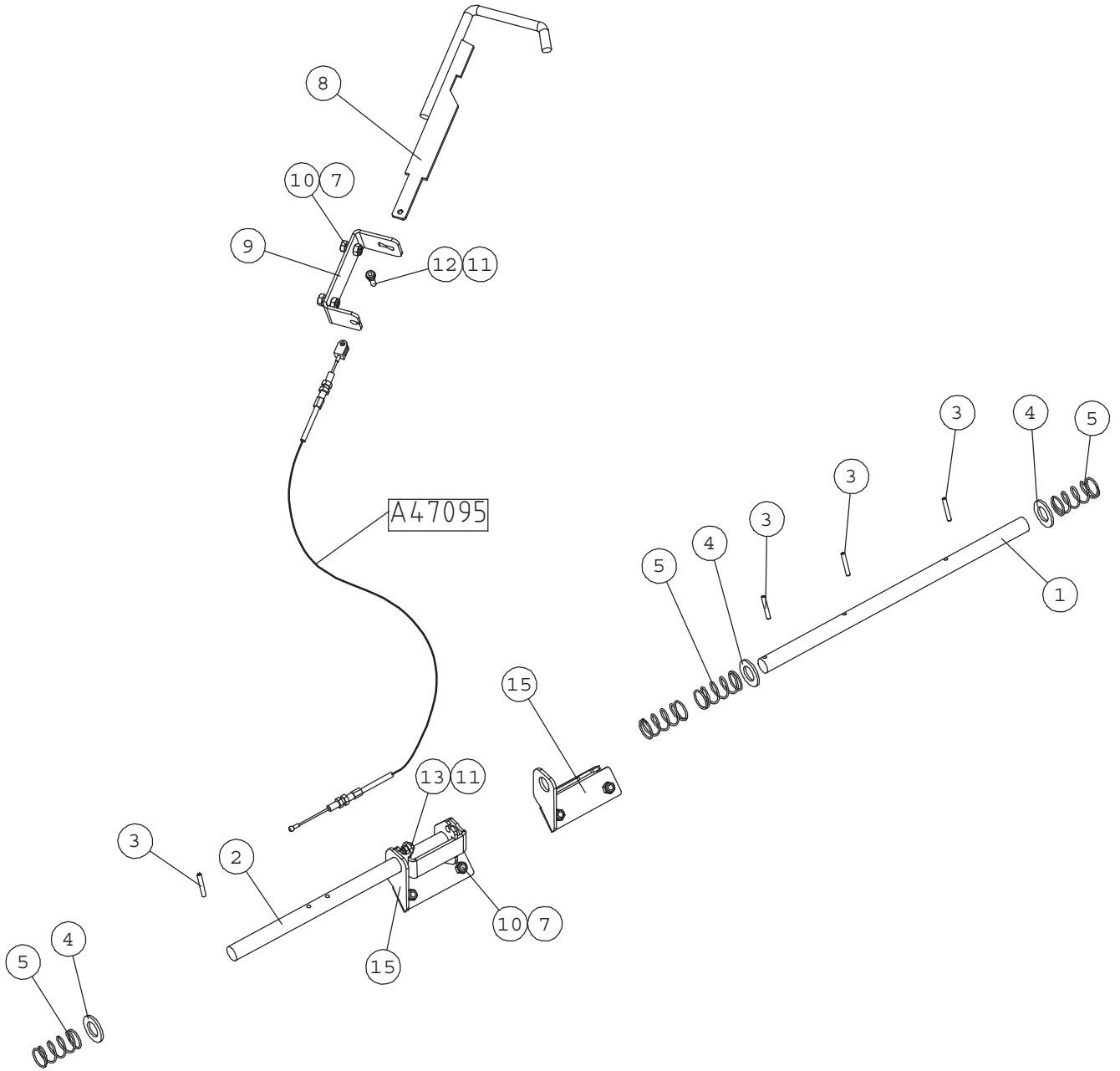

A35461 PARKING BRAKE, ASSEMBLY

Before serial number XXXXX1342

NRO REF POS TEIL	OSAN NRO PART NO BESTÄLL.NR BEST.NR	KPL QTY ST ST	NIMITYS	DESCRIPTION	BENÄMNING	BEZEICHNUNG
1	A47011	1	LUKITUSTAPPI , OIKEA	LOCKING PIN, RIGHT,	LÄSTAPP, HÖGER, PARK	VERRIEGELUNGSBOLZEN,
2	A414872	1	LUKITUSTAPPI KP , VA	LOCKING PIN, LEFT, P	LÄSTAPP, VÄNSTER, PA	VERRIEGELUNGSBOLZEN,
3	71792	4	JOUSISOKKA	SPRING COTTER PIN 5	FJÄDERSPRINT 5x32	FEDERSPLINT 5x 32 DI
4	73123	3	ALUSLEVY M20	WASHER M20 DIN 125 Z	BRICKA M20 DIN 125	UNTERLEGSSCHEIBE M20
5	64138	4	PURISTUSJOUSI, DIN	COMPRESSION SPRIG DI	TILLHÄLLARFJÄDER DIN	DRUCKFEDER DIN 2098
6	73122	4	ALUSLEVY M 8	WASHER M8 A8	BRICKA M8 A8,	UNTERLEGSSCHEIBE M8
7	72320	6	KUUSIOMUTTERI ZN	NUT M8 NYLOC DIN 98	SEKKANTMUTTER M8 NY	SECHSKANTMUTTER M 8
8	A47090	1	VETOKAHVA	LATCH, PARKING BRAKE	REGEL, PARKERINGSBRO	RIEGEL, FESTSTELLBRE
9	A47087	1	OHJURI	BRACKET, PARKING BRA	FÄSTE, PARKERINGSBRO	AUFNAHME, FESTSTELLB
10	72130	6	KUUSIORUUVI ZN	HEXAGONAL SCREW M8x2	SEKKANTSKRUV M8x20 D	SECHSKANTSCHRAUBE M
11	72318	2	KUUSIOMUTTERI	SIXTH NUT M 6 DIN 98	SEKKANTMUTTER M6 NY	SECHSKANTMUTTER M 6
12	72118	1	KUUSIORUUVI ZN	HEXAGONAL SCREW M6x2	SEKKANTSKRUV M6x20 D	SECHSKANTSCHRAUBE M
13	72116	1	KUUSIORUUVI ZN	HEXAGONAL SCREW M 6x	SEKKANTSKRUV M 6x12	SECHSKANTSCHRAUBE M
14	A47095	1	KÄSIJARRUNVAIJERI 60	PARKING BRAKE WIRE L	VAJER, HANDBROMS L=	HANDBREMSSEIL L=1090
15	A414804	2	KIINNIKE	BRACKET	FÄSTE	AUFNAHME

A415984 LOAD SENSOR SYSTEM, COMPLETE

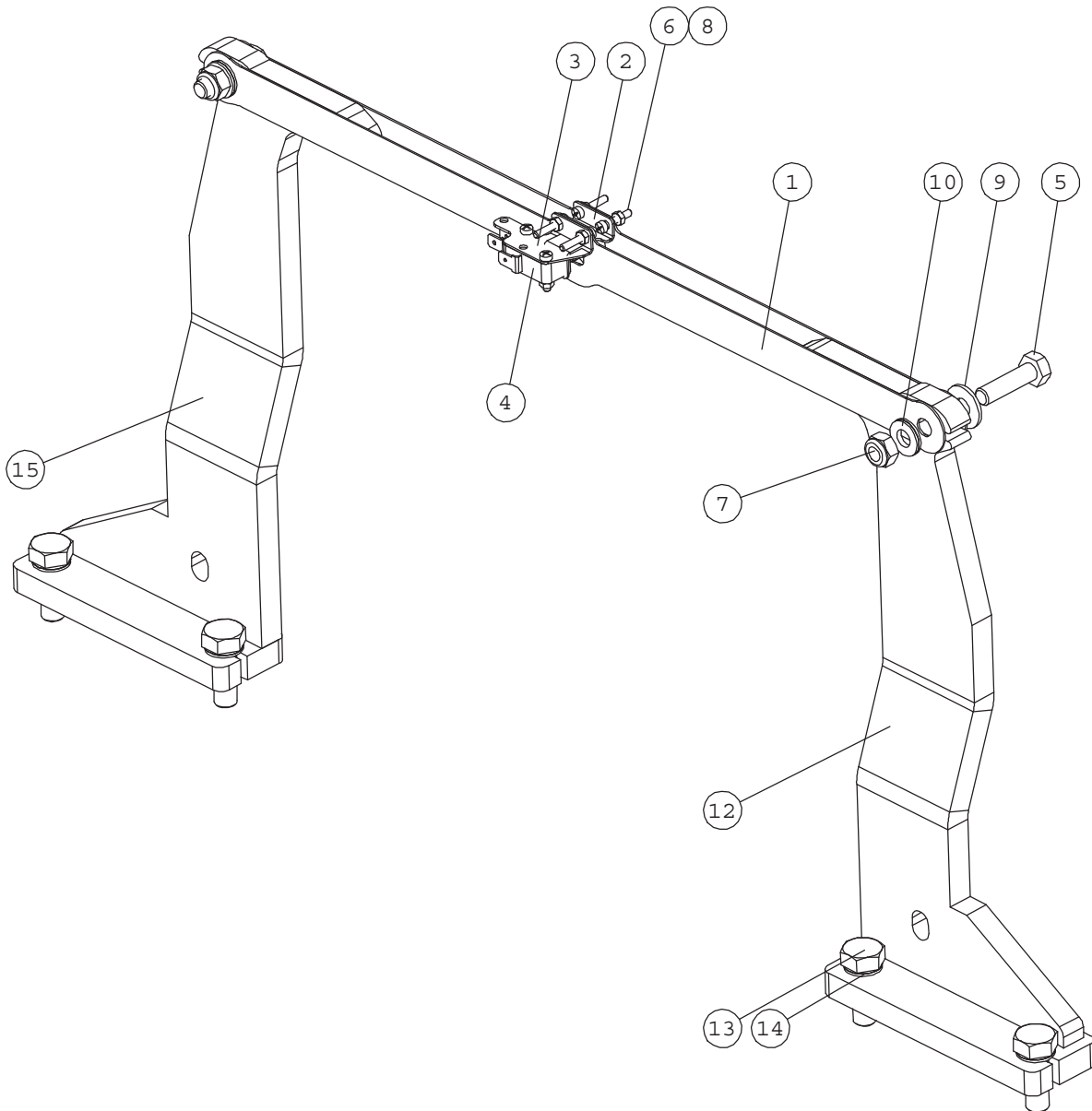

NRO REF POS TEIL	OSAN NRO PART NO BESTÄLL.NR BEST.NR	KPL QTY ST ST	NIMITYS	DESCRIPTION	BENÄMNING	BEZEICHNUNG
1	A47912	2	LISTA	BAND	BAND	STREIFEN
2	A47908	1	KYNSI	CLAW	KLO	NAGEL
3	A47909	1	KIINNIKE	BRACKET, MICROSWITCH	FÄSTE, MIKROBRYTARE	AUFNAHME, MIKROSCHAL
4	64504	1	MIKROKYTKIN OMRON V1	MICROSWITCH OMRON V1	MIKROBRYTARE OMRON V	MIKROSCHALTER OMRON
5	72133	2	KUUSIORUUVI ZN	HEXAGONAL SCREW M8×3	SEKANTSKRUV M8×30 D	SECHSKANTSCHRAUBE M
6	74576	6	RISTIURARUUVI	PAN HEAD MACHINE SCR	KRYSSPÅRSKRUV M3×16	LINSENSCHRAUBE MIT K
7	72320	2	KUUSIOMUTTERI ZN	NUT M8 NYLOC DIN 98	SEKANTMUTTER M8 NY	SECHSKANTMUTTER M 8
8	74535	6	KUUSIOMUTTERI	HEXAGONAL NUT M3	SEKANTMUTTER M3	SECHSKANTMUTTER M3
9	74525	2	ALUSLEVY M 8	WASHER M8 8,4×20×1,	BRICKA M8 8,4×20×1,	UNTERLEGSCHIEBE M8
10	63944	2	ALUSLEVYPARI M 8	WASHER, PAIR, NORD-L	BRICKA NORD-LOCK M8,	UNTERLEGSCHIEBE, PAA
11	64955	1	SUMMERI SONITRON	ALARM BEEPER SONITRO	VARNINGSSUMMER SONIT	WARNUNGSSUMMER SONIT
12	A415985	1	AISA KP, VASEN	BRACKET, LEFT, LOAD	FÄSTE, VÄNSTER, LAST	HALTERUNG, LINKS, LA
13	72151	4	KUUSIORUUVI ZN	HEXAGONAL SCREW M10×	SEKANTSKRUV M10×30	SECHSKANTSCHRAUBE M1
14	74531	4	ALUSLEVYPARI M10	SPACER NORDLOCK M10,	BRICKA NORDLOCK M10,	UNTERLEGSCHIEBE NORD
15	A415986	1	AISA KP, OIKEA	BRACKET, RIGHT, LOAD	FÄSTE, HÖGER, LASTÖV	HALTERUNG, RECHTS, L

A413932 FUEL TANK 30 L

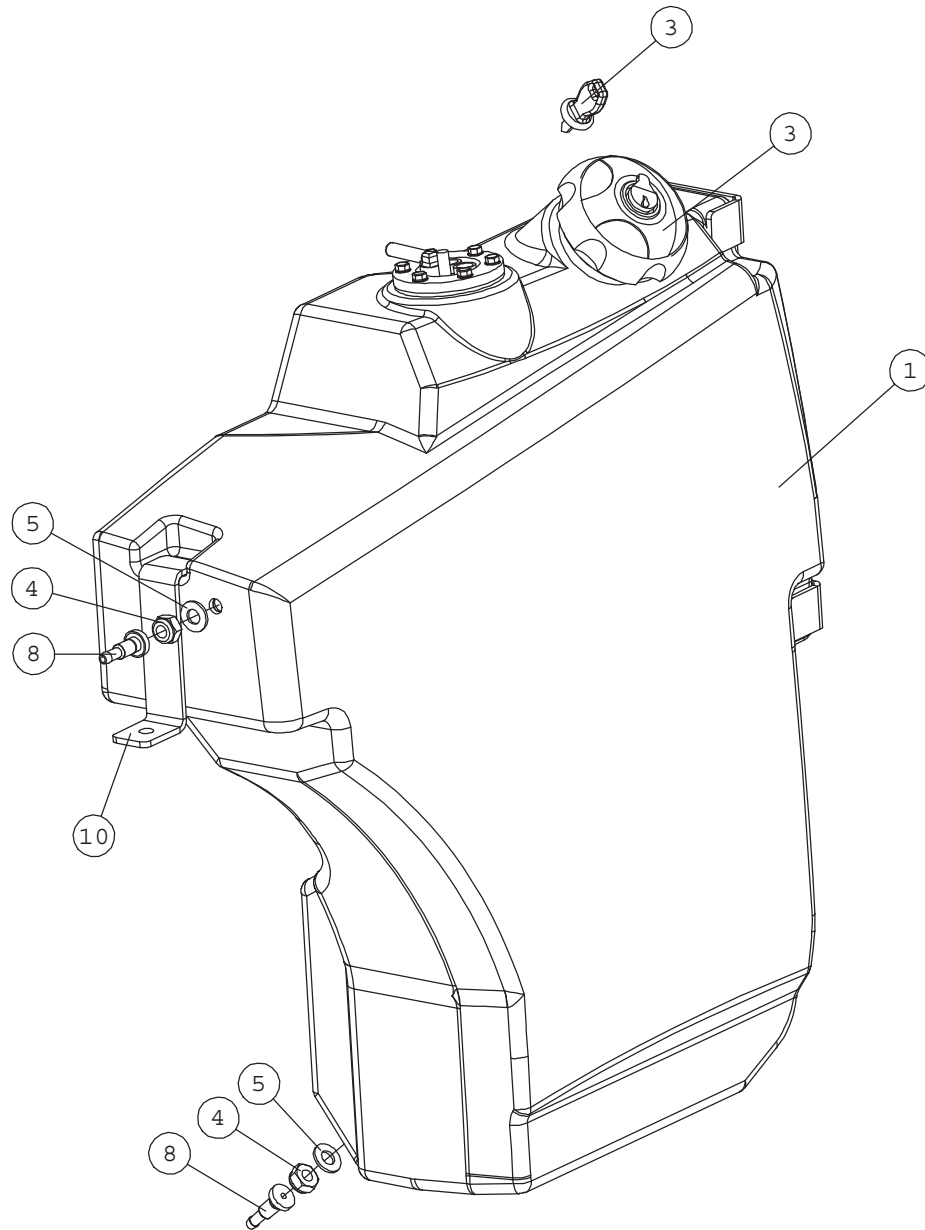

NRO REF POS TEIL	OSAN NRO PART NO BESTÄLL.NR BEST.NR	KPL QTY ST ST	NIMITYS	DESCRIPTION	BENÄMNING	BEZEICHNUNG
1	A413512	1	POLTTOAINETANKKI 30L	FUEL TANK 30L , 20	BRÄNSLETANK 30L, 20	KRAFTSTOFFBEHÄLTER 3
2	64977	1	PA-MITTARIN ANTURI	SENSOR, FUEL GAUGE C	GIVARE, BRÄNSLEMÄTAR	GEBER, KRAFTSTOFFANZ
3	A410521	1	LUKITTAVA TANKINKORK	FUEL TANK CAP, LOCKA	TANKLOCK LÄSBAR	TANKDECKEL, ABSCHLIE
4	72322	2	KUUSIOMUTTERI	HEXAGONAL NUT M12 D	SEXXKANTMUTTER M12 D	SECHSKANTMUTTER M12
5	73121	2	ALUSLEVY M10 A10,5	WASHER M10 A10,	BRICKA M10 A	UNTERLEGSCHIBE M10
6	74773	6	PORARUUVI ZN	SELF-DRILLING HEXAGO	SJÄLVBORRANDE SKRUV	SELBSTBOHRENDE SECHS
7	74774	2	O-RENGAS NBR	O-RING NBR F 10x3	O-RING NBR F 10x3	O-RING NBR F 10x3
8	a43531	2	POLTTO-AINEKARA F7MM	NIPPLE F7MM	NIPPEL F7 MM	NIPPEL, KRAFTSTOFFSC
9	A413674	1	TANKINKANNAKE	BRACKET, FUEL TANK	FÄSTE, BRÄNSLETANK	AUFNAHME, KRAFTSTOFF
10	a47553	1	SALPA	LATCH	REGEL	RIEGEL

A34234 HYDRAULIC MANIFOLD

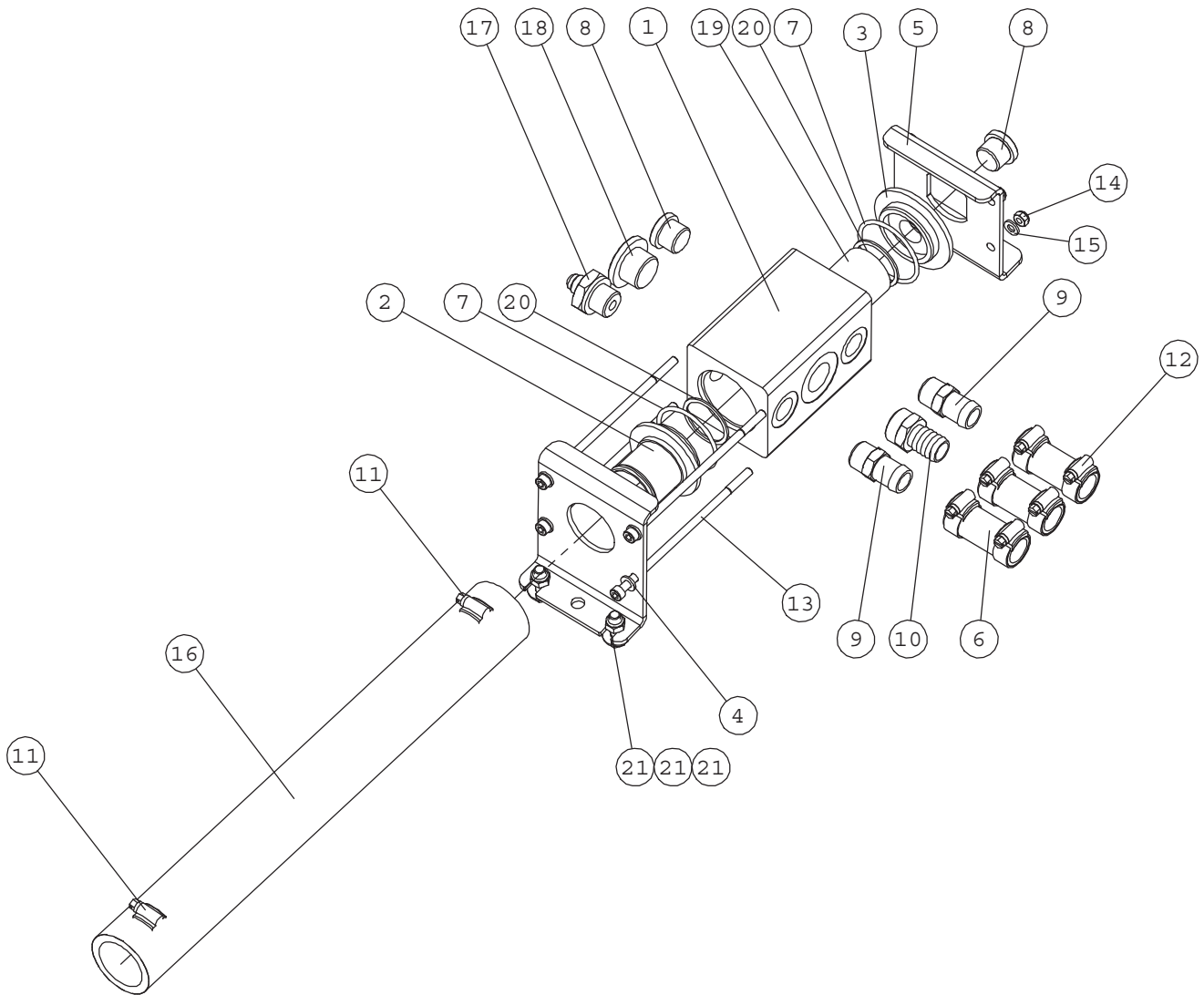

NRO REF POS TEIL	OSAN NRO PART NO BESTÄLL.NR BEST.NR	KPL QTY ST ST	NIMITYS	DESCRIPTION	BENÄMNING	BEZEICHUNG
1	A47181	1	IMUTUKKI	HYDRAULIC MANIFOLD	HYDRAULBLOCK	HYDRAULIKVERTEILER
2	A47256	1	IMUKARA	SUCTION PIPE, MANIFO	SUGRÖR, HYDRAULIKBLO	SAUGROHR, HYDRAULIKV
3	A47257	1	TULPPA	PLUG	PROPP	PROPFEN
4	A47254	1	ETUJALKA	BRACKET, FRONT, HYDR	FÄSTE, FRAM, HYDRAUL	AUFNAHME, VORNE, HYD
5	A47255	1	TAKAJALKA	BRACKET, REAR, HYDRA	FÄSTE, BAK, HYDRAULI	AUFNAHME, HINTEN, HY
6	A47767	3	IMULETKU D=20 L=350	INLET HOSE D=20 L=25	SUGSLANG D=20 L=250	SAUGSCHLAUCH D=20 L=
7	74739	2	O-RENGAS NBR	O-RING NBR F 50,2 x	O-RING NBR F 50,2 x	O-RING NBR F 50,2 x
8	64174	2	KUUSIOKOLOTULPPA	HEXAGONAL DRAIN PLUG	SEKANTPLUGG HF 1/2"	HYDR. TANKABLASSSCHR
9	64110	2	LETKUKARA	HOSE COUPLING R1/2"U	SLANGKOPPLING R1/2"U	SCHLAUCHVERSCHR. R1/
10	64915	1	LETKUKARA	HOSE FITTING R3/4"UK	SLANGKOPPLING R3/4"U	SCHLAUCHNIPPEL R3/4"
11	64338	2	LETKUNKIRISTIN ABA	HOSE CLAMP ABA 44-56	SLANGKLAMMA ABA 44-5	SCHLAUCHKLEMME ABA 4
12	73530	6	LETKUNKIRISTIN ABA	HOSE CLAMP 22-32 MM	SLANGKLAMMARE 22-32	SCHLAUCHKLEMME 22-32
13	74743	4	KUUSIOKOLORUUVI	HEXAGON. HEAD SCREW	SEKANTHÄLSKRUV M 6x	INNEN-SECHSKANTSCHR.
14	72318	4	KUUSIOMUTTERI	SIXTH NUT M 6 DIN 98	SEKANTMUTTER M6 NY	SECHSKANTMUTTER M 6
15	71680	8	ALUSLEVY M 6	WASHER M6 DIN 125	BRICKA M6 A6,4 DIN 1	UNTERLEGSCHIEBE M6 A
16	A410028	1	IMULETKU F53/F40-440	INLET HOSE F53/F40-	SUGSLANG F53/F40-44	SAUGSCHLAUCH F53/F40
17	64040	1	PERUSLIITIN	BASIC FITTING F40X	RAK KOPPLING F40XS	GERADE EINSCHR. F40X
18	73768	1	KUUSIOKOLOTULPPA	HEXAGONAL PLUG HF-3/	SEKANTPROPP HF-3/4"	HYDR. TANKABLASSSCHRA
19	A411260	1	IMUSIHTI	SUCTION STRAINER	SUGSIL	SAUGSIEB
20	A411261	2	TASOTIIVISTE	SEAL RING	TÄTNING	DICHTUNG

A34366 MULTI CONNECTOR

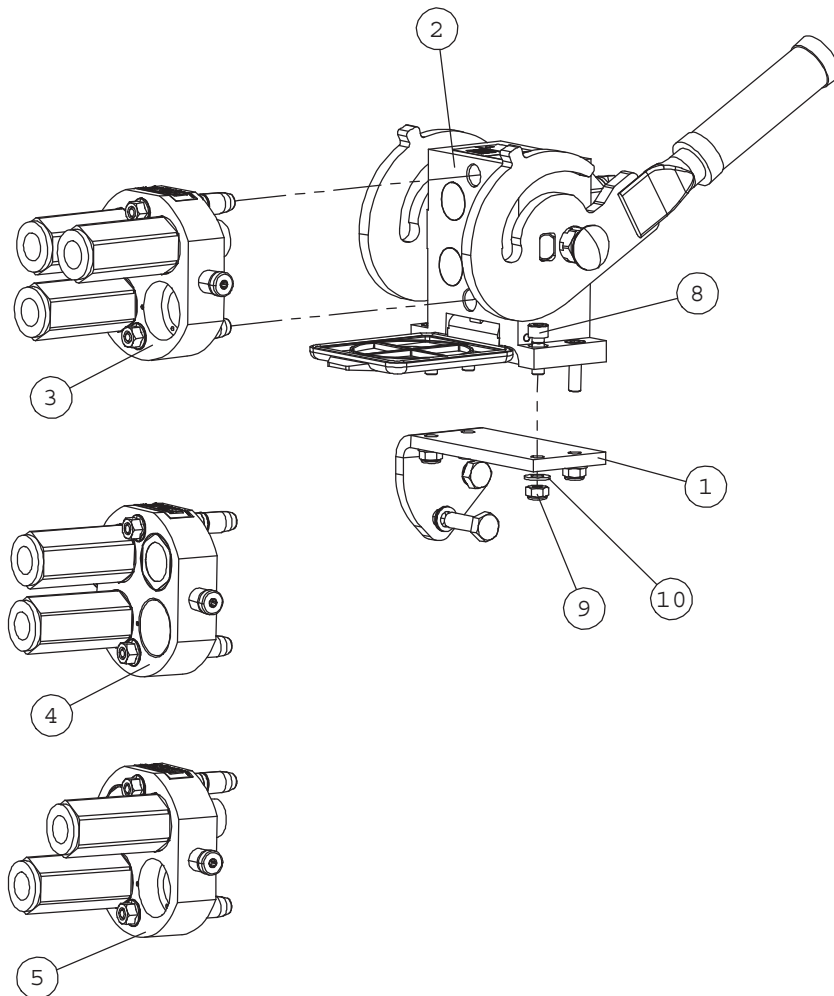

NRO REF POS TEIL	OSAN NRO PART NO BESTÄLL.NR BEST.NR	KPL QTY ST ST	NIMITYS	DESCRIPTION	BENÄMNING	BEZEICHNUNG
1	A410804	1	PIKALIITIN KIINNIKE	MOUNTING BRACKET, MU	FÄSTE, FLERSNABBKOPP	AUFNAHME, MULTI-KUPPL
2	65252	1	PIKALIITINRYHMÄ 3P5	MULTI CONNECTOR, ON	FLERSNABBKOPPLING, L	MULTI-KUPPLUNG, LADE
3	65250		PIKALIITINRYHMÄ	MULTI CONNECTOR, 3 C	FLERKOPPLING, 3 KOPP	MULTI-KUPPLUNG, 3 KU
4	65251		PIKALIITINRYHMÄ	MULTI CONNECTOR, 2 C	FLERKOPPLING, 2 KOPP	MULTI-KUPPLUNG, 2 KU
5	65371		PIKALIITINRYHMÄ	MULTI CONNECTOR, 2 C	FLERKOPPLING, 2 KOPP	MULTI-KUPPLUNG, 2 KU
	65627		PIKALIITIN UROS	CHECK VALVE CARTRIDG	KONTRASTVENTILPATRON	RÜCKSCHLAGVENTIL -PAT
6	74505	2	KUUSIORUUVI ZN	HEXAGONAL SCREW M10x	SEXXANTSKRUV M10x35	SECHSKANTSCHRAUBE M1
7	64058	3	PERUSLIITIN	BASIC FITTING F40XS1	RAK KOPPLING F40XS12	GERADE EINSCHRAUBVER
8	71884	4	KUUSIOKOLORUUVI	HEXAGONAL SCREW M	SEXXANTHÄLSKRUV M	INNENSECHSKANT - SCH
9	72320	4	KUUSIOMUTTERI ZN	NUT M8 NYLOC DIN 98	SEXXANTMUTTER M8 NY	SECHSKANTMUTTER M 8
10	73122	4	ALUSLEVY M 8	WASHER M8 A8	BRICKA M8 A8,	UNTERLEGSCHIEBE M8
11	74531	2	ALUSLEVYPARI M10	SPACER NORDLOCK M10,	BRICKA NORDLOCK M10,	UNTERLEGSCHIEBE NORD

A49124 WIRE HARNESS

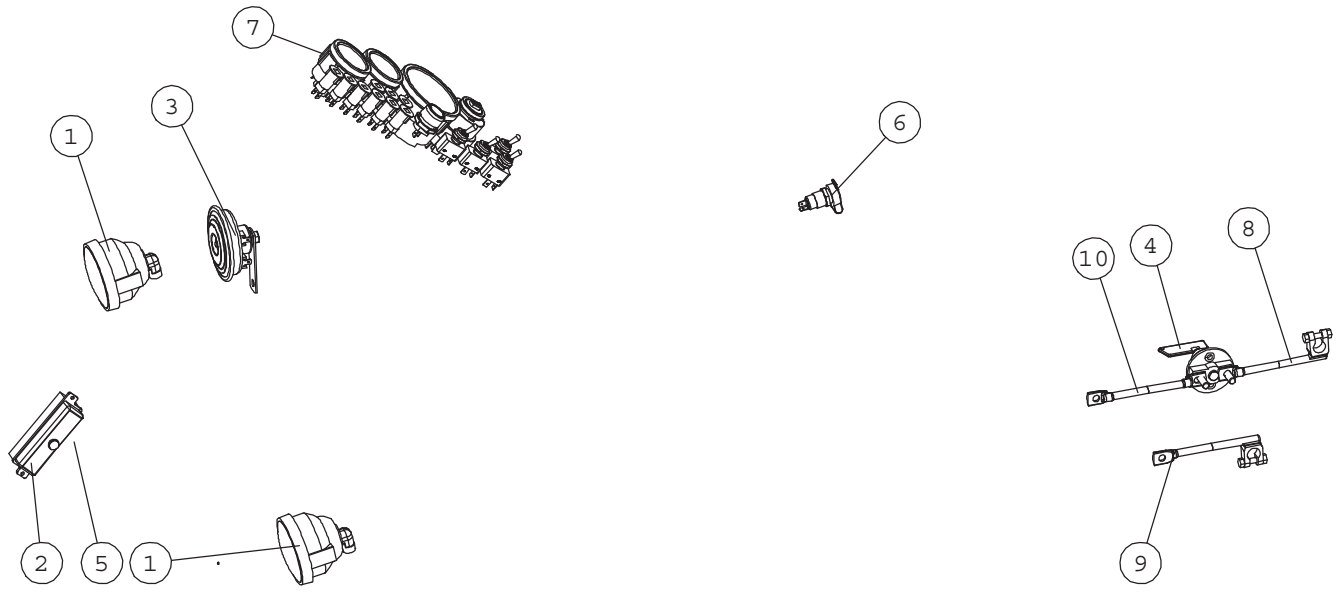

A49124 WIRE HARNESS

NRO REF POS TEIL	OSAN NRO PART NO BESTÄLL.NR BEST.NR	KPL QTY ST ST	NIMITYS	DESCRIPTION	BENÄMNING	BEZEICHNUNG
1	64785	2	TYÖVALAISIN COBO	WORK LIGHT COBO 12V/	ARBETSLJUS COBO 12V/	ARBEITSLEUCHTE COBO
2	64943	1	SULAKEPESA, 6 SULAK	FUSE BOX, FOR 6 FUSE	SAKRINGSASK, FÖR 6 S	SICHERUNGSKASTEN, FÜ
3	64157	1	ÄÄNIMERKKI 12 V DC	SIGNAL HORN COMPLETE	SIGNALHORN KOMPLETT	HUPE KOMPLETT
4	64141	1	PÄÄVIRTAKYTKIN	BATTERY DISCONNECT S	HUVUDSTRÖMBRYTARE C-	HAUPTSCHALTER C-1802
5	A47763	1	SULAKERASIAN KANNAKE	BRACKET, FUSE BOX	FÄSTE, SÄKRINGSASK	AUFNAHME, SICHERUNGS
6	64213	1	PISTORASIA	OUTLET MERIT (114320	STICKDOSA MERIT (114	STECKDOSE MERIT (114
7	a49126	1	MITTARIPANEELI	DASHBOARD 500/600 SE	INSTRUMENTBRÄDA 500/	ÄRMATURENBRETT 500/6
8	65071	1	KAAPELI,AKKU, MUSTA	CABLE, BATTERY, BLAC	KABEL, BATTERI, SVAR	KABEL, BATTERIE, SCH
9	65070	1	KAAPELI,AKKU, PUNAI	CABLE, BATTERY, RED,	KABEL, BATTERI, RÖD,	KABEL, BATTERIE, ROT
10	65069	1	KAAPELI,AKKU, MUSTA	CABLE, BATTERY, BLAC	KABEL, BATTERI, SVAR	KABEL, BATTERIE, SCH
11	A21283	1	SÄHKÖSARJA AVANT600			

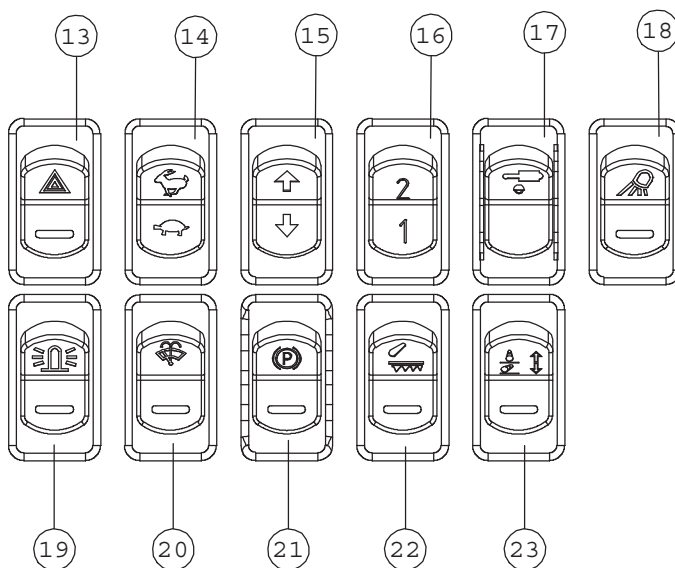

NRO REF POS TEIL	OSAN NRO PART NO BESTÄLL.NR BEST.NR	KPL QTY ST ST	NIMITYS	DESCRIPTION	BENÄMNING	BEZEICHNUNG
13	65064	1	KYTKIN COBO	SWITCH, WARNING BLIN	BRYTARE, VÄRNINGSBLI	SCHALTER, WARNBLINKE
14	65246	1	KYTKIN COBO	SWITCH, DRIVE SPEED	BRYTARE, KÖRHASTIGHE	SCHALTER, 1/2. FAHR
15	65476	1	KYTKIN COBO	SWITCH, 2 DIRECTIONS	BRYTARE, 2 RIKTNINGA	SCHALTER, RICHTUNGEN
16	65276	1	KYTKIN COBO	ROCKER SWITCH, REAR	VIPPBRYTARE, HYDR. U	WIPPSCHALTER, ZUSATZ
17	65448	1	KYTKIN COBO	ROCKER SWITCH, HYDR.	VIPPBRYTARE, HYDR. R	WIPPSCHALTER, HYDR.
18	65066	1	KYTKIN COBO	SWITCH, WORK LIGHT	BRYTARE, ARBETSLJUS	SCHALTER, ARBEITSLIC
19	65065	1	KYTKIN COBO	SWITCH, BEACON	BRYTARE, ALARMBLINKL	SCHALTER, RUNDUMLEUC
20	65063	1	KYTKIN COBO	SWITCH, WIPER/WASHER	BRYTARE, VINDRUTETOR	SCHALTER, WISCHER /
21	65216	1	KYTKIN COBO	SWITCH, PARKING BRAK	BRYTARE, PARKERINGSB	SCHALTER, FESTSTELLB
22	65277	1	KYTKIN COBO	ROCKER SWITCH, FLOAT	VIPPBRYTARE, FLYTLÄG	WIPPSCHALTER, SCHWIM
23	65278	1	KYTKIN COBO	ROCKER SWITCH, HYDR.	VIPPBRYTARE, HYDR. B	WIPPSCHALTER, HYDR.

A49126 DASHBOARD

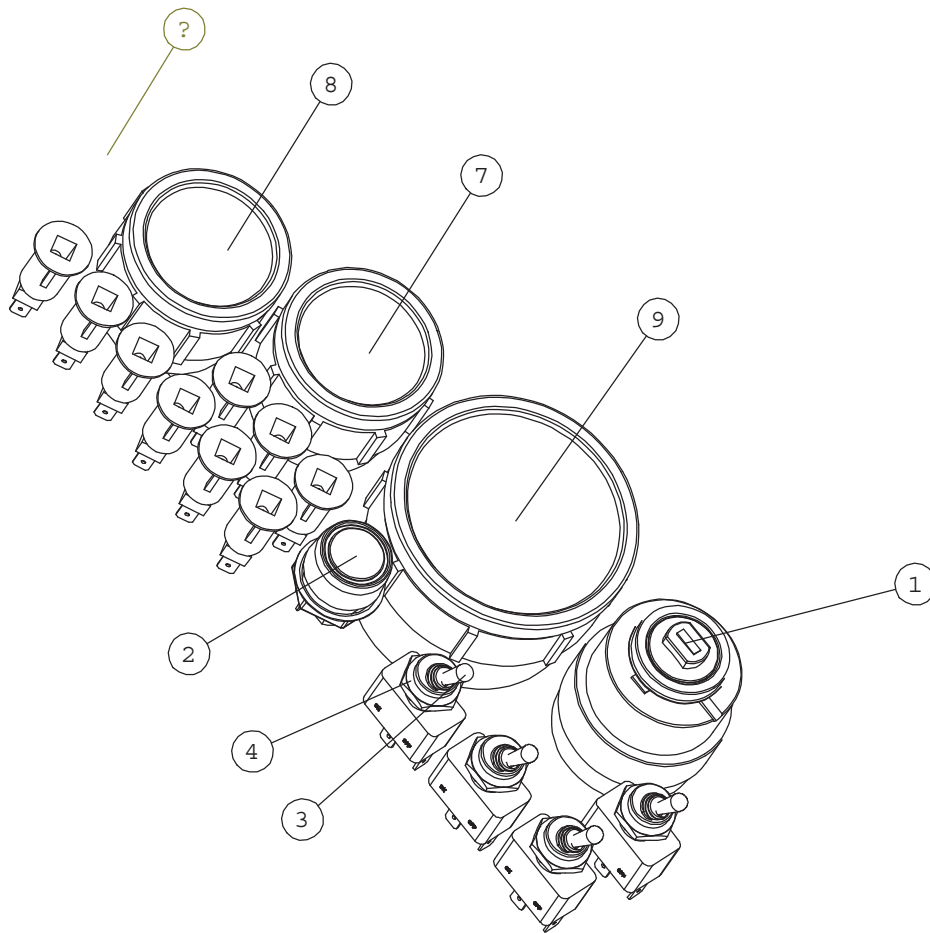

A49126 DASHBOARD

NRO REF POS TEIL	OSAN NRO PART NO BESTÄLL.NR BEST.NR	KPL QTY ST ST	NIMITYS	DESCRIPTION	BENÄMNING	BEZEICHNUNG
1	64202	1	VIRTALUKKO EAK4438	IGNITION SWITCH FOR	TÄNDLÅS MERIT 330332	ZÜNDSCHALTER MERIT 3
2	64074	1	PAINOKYTKIN, F22,5	PUSH BUTTON F22,5 SI	TRYCKKNAPP F22,5 SIG	DRUCKKNOPF F22,5 HUP
3	64602	4	VIPIKYTKIN B067AP 2	DISC SPRING SF-TAF	TALLRIKSFJÄDER SF-TA	TELLERFEDER SF-TAF 3
4	64603	4	KUMISUOJUS V-22 VIPU	RUBBER COVER V-22, T	GUMMISKYDD V-22, VIP	SCHUTZGUMMI V-22, KI
5	A49125	1	MITTARIPIPANEELIN	PLATE, DASHBOARD	BOTTENPLATTA, INSTRU	PLATTE, ARMATURENBRE
6	_polttimoco bo	9	POLTTIMO	BULB	GLÖDLAMPA	BIRNE
7	65121	1	LÄMPÖMITTARI, VESI	THERMOMETER, WATER	TERMOMETER, VATTEN	THERMOMETER, WASSER
8	65122	1	POLTTOAINEMITTARI	FUEL GAUGE	BRÄNSLEMÄTARE	KRAFTSTOFFANZEIGE
9	65123	1	KIERROSLUK/TUNTIMITT	HOURLY METER/TACHOMETE	TIMMÄTARE/VARVMÄTARE	STUNDENZÄHLER/DREHZA

A34144 BOOM SELF LEVELLING

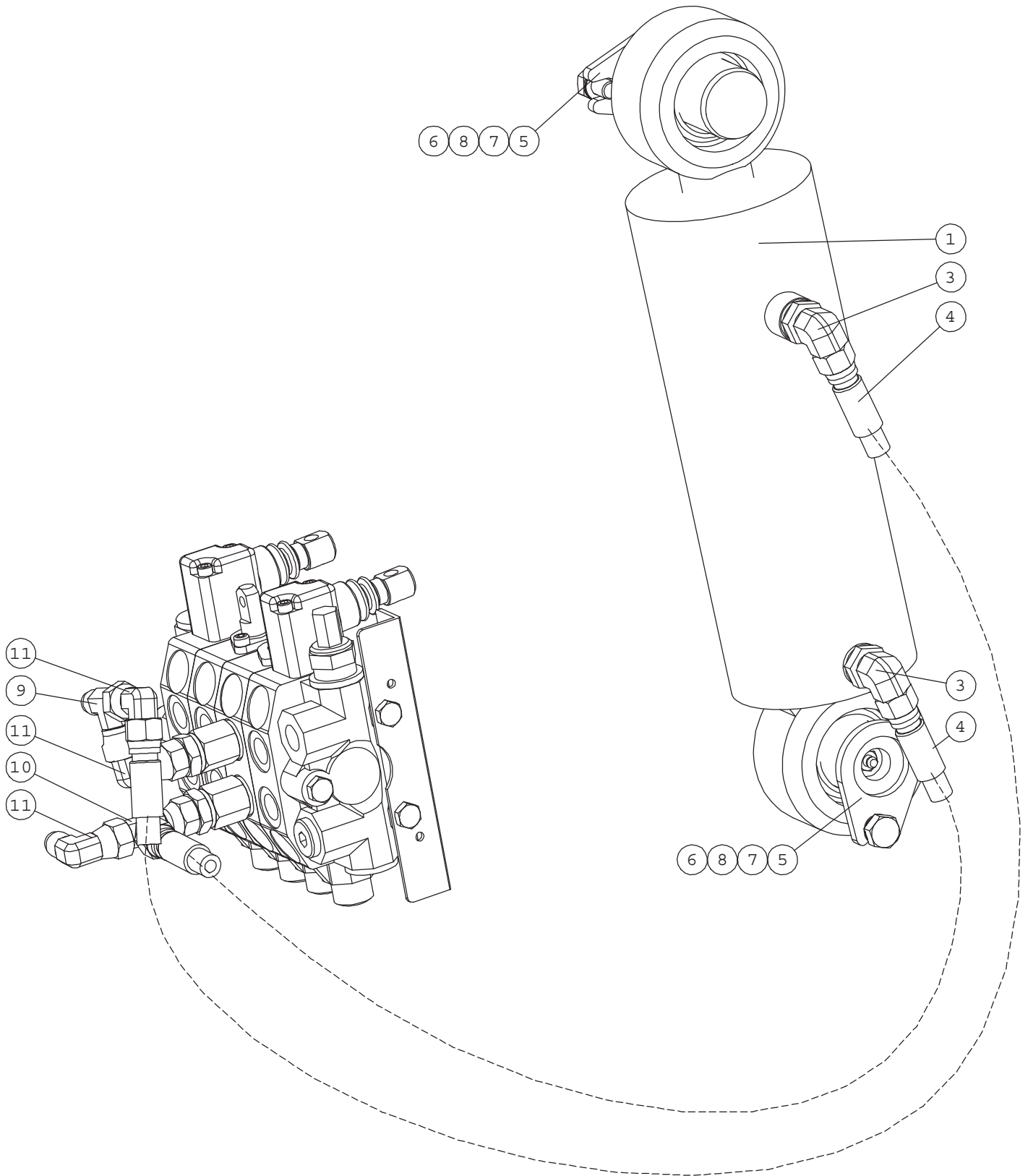

A34144 BOOM SELF LEVELLING

NRO REF POS TEIL	OSAN NRO PART NO BESTÄLL.NR BEST.NR	KPL QTY ST ST	NIMITYS	DESCRIPTION	BENÄMNING	BEZEICHNUNG
1	A47920	1	HYDR.SYL F90/F40-146	HYDR. CYLINDER F90/F	HYDRAULCYLINDER F90/	HYDRAULIKZYLINDER F9
	65005		TIIVISTESARJA YAS904	SEAL KIT, CYLINDER 9	PACKNINGSSATS CYLIND	DICHTSATZ, ZYLINDER
3	64044	2	KULMALIITIN 90 AST	ELBOW FITTING 90 DE	VINKELKOPPLING 90 GR	WINKEL EINSCHRAUBVER
4	A47640	2	HYDR.LETKU L=2050 2L	HYDR. HOSE L=2050 2L	HYDRAULSLANG L=2050	HYDR. SCHLAUCH L=205
5	A47041	2	TAPPI KP F40-90	PIVON PIN F40-90	AXELTAPP F40-90	GELENKBOLZEN F40-90
6	72798	2	RASVANIPPA DIN 71412	GREASE NIPPLE R 1/8	SMÖRJNIPPEL R 1/8"	SCHMIERNIPPEL R1/8
7	72147	2	KUUSIORUUVI ZN	HEXAGONAL SCREW M 10	SEKANTSKRUV M 10x16	SECHSKANTSCHRAUBE M
8	74531	2	ALUSLEVYPARI M10	SPACER NORDLOCK M10,	BRICKA NORDLOCK M10,	UNTERLEGSCHEIBE NORD
9	64070	1	T-KIERRELIITINRUNKO	T-SPIRAL CONNECTION	T-SPIRAL KOPPLING RA	T-VERSCHRAUBUNG S6XS
10	64078	1	L-LIITINRUNKO	L-FITTING BODY R6XS1	L-KOPPLING RAM R6XS	L - VERSCHRAUBUNG R6
11	64043	3	KULMALIITIN 90 AST	ELBOW FITTING 90 DE	VINKELKOPPLING 90 GR	WINKEL EINSCHRAUBVER

A34015 BOOM FLOATING, WHEN SELF LEVELING

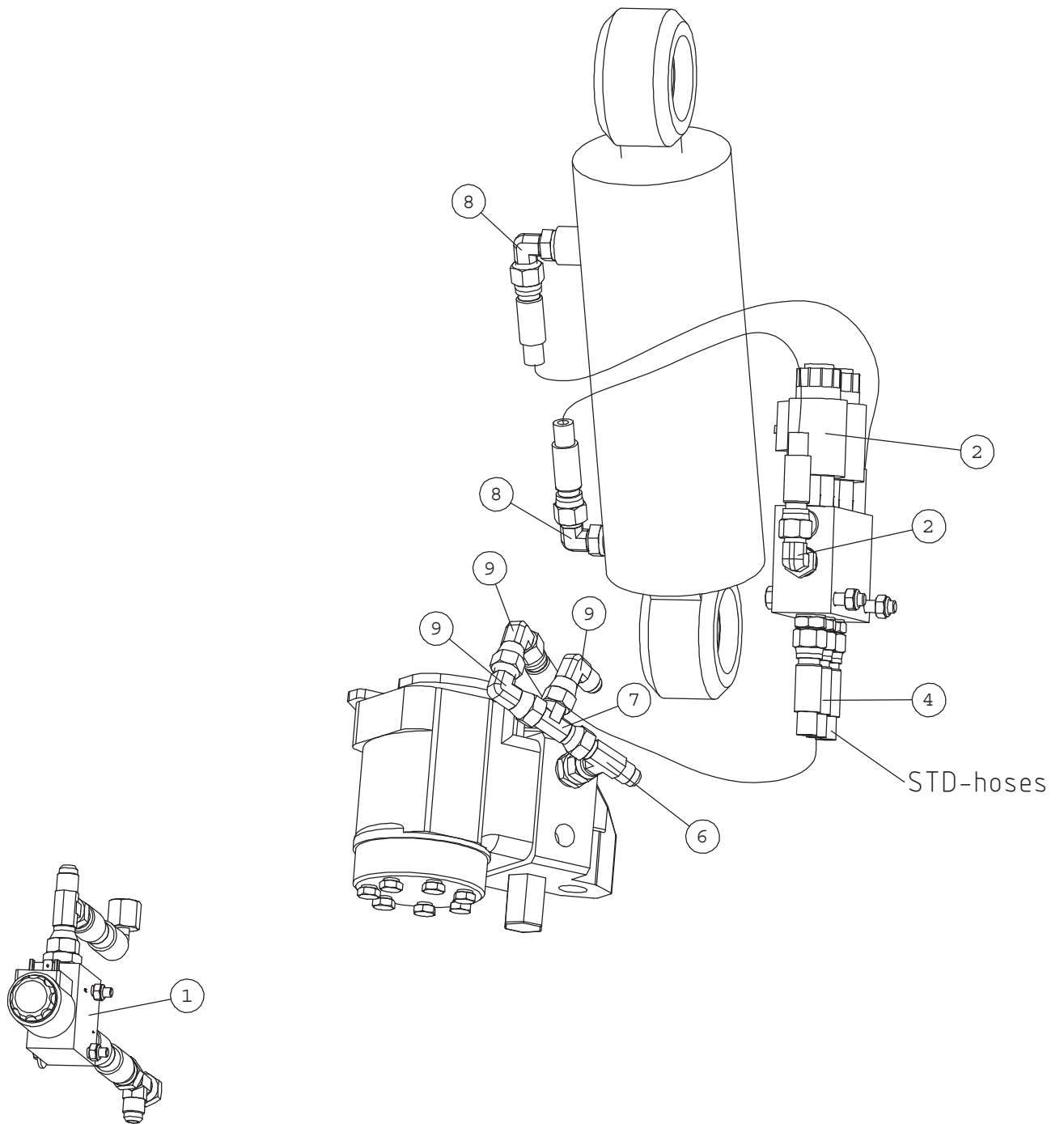

A34015 BOOM FLOATING, WHEN SELF LEVELING

NRO REF POS TEIL	OSAN NRO PART NO BESTÄLL.NR BEST.NR	KPL QTY ST ST	NIMITYS	DESCRIPTION	BENÄMNING	BEZEICHNUNG
1	A47773	1	PUOMINKELLUNTA KP	BOOM FLOATING, MACHI	FLYTLÄGE, BOM, MASKI	SCHWIMMSTELLUNG, MAS
2	A413297	1	VENTTIILI KP	VALVE, BOOM FLOATING	VENTIL, FLYTLÄGE/PAR	VENTIL, SCHWIMMSTELL
3	A44472	2	HYDR.LETKU L=720 1LW	HYDR. HOSE L=720 JIC	HYDR. SLANG L=720 JI	HYDR.SCHLAUCH L=720
4	A44471	1	HYDR.LETKU L=400 1LW	HYDR. HOSE L=400 JIC	HYDR. SLANG L=400 JI	HYDR.SCHLAUCH L=400
5	A49716	1	SÄHKÖSARJA	WIRE HARNESS, BOOM F	KABELHÄRVA, FLYTLÄGE	KABELBAUM, SCHWIMMST
6	64070	1	T-KIERRELIITINRUNKO	T FITTING S6XS10	T-KOPPLING S6XS10	T-VERSCHRAUBUNG S6XS
7	64078	1	L-LIITINRUNKO	L-FITTING BODY R6XS1	L-KOPPLING RAM R6XS	L - VERSCHRAUBUNG R6
8	64087	2	KULMALIITIN 90 AST.	ELBOW FITTING 90 DEG	VINKELKOPPLING 90 GR	WINKEL-VERSCHR. C40X
9	64043	3	KULMALIITIN 90 AST	ELBOW FITTING 90 DE	VINKELKOPPLING 90 GR	WINKEL-VERSCHR. C6XS

A47773 BOOM FLOATING, MACHINE WITHOUT SELF LEVELING

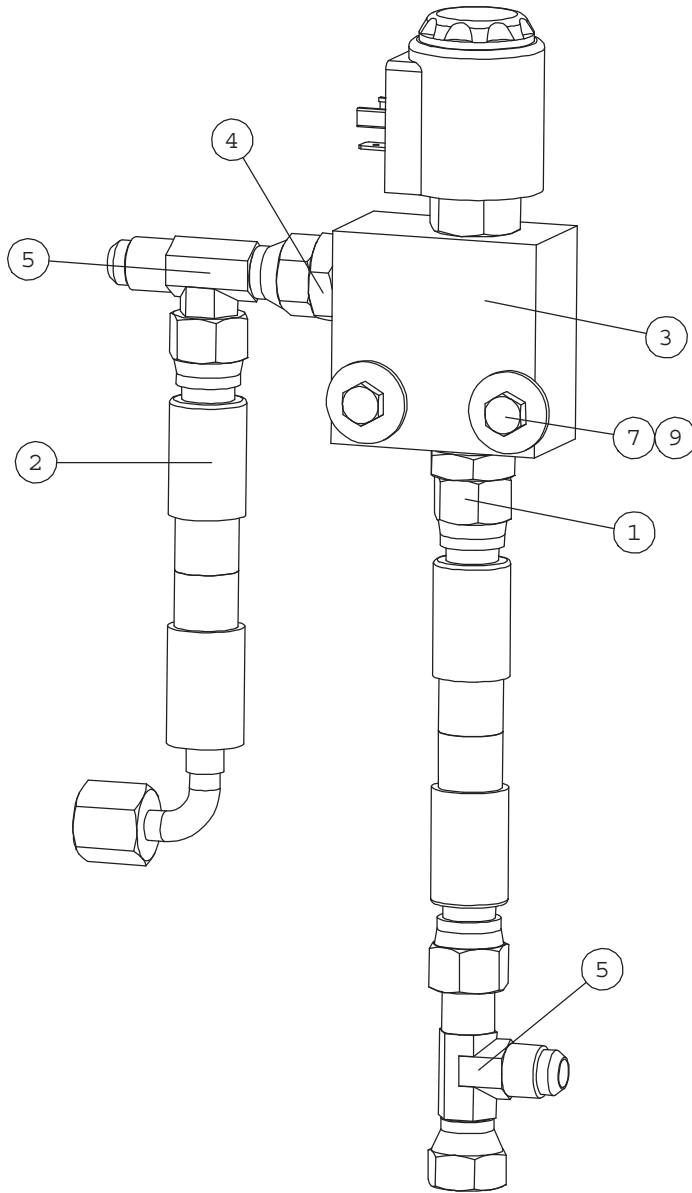

A47773 BOOM FLOATING, MACHINE WITHOUT SELF LEVELING

NRO REF POS TEIL	OSAN NRO PART NO BESTÄLL.NR BEST.NR	KPL QTY ST ST	NIMITYS	DESCRIPTION	BENÄMNING	BEZEICHNUNG
1	A47916	1	HYDR.LETKU L=900	HYDR. HOSE L=900 1LW	HYDRAULSLANG L=900 1	HYDR. SCHLAUCH L=900
2	A47907	1	HYDR.LETKU L=980	HYDR. HOSE L=980 2LW	HYDRAULSLANG L=980 2	HYDR. SCHLAUCH L=980
3	64676	1	SOLENOIDIVENTTIILI	SOLENOID VALVE WK08W	MAGNETVENTIL WK08W-0	MAGNETVENTIL WK08W-0
4	64041	2	PERUSLIITIN	BASIC FITTING F40X	RAK KOPPLING F40XS	GERADE EINSCHR. F40X
5	64078	2	L-LIITINRUNKO	L-FITTING BODY R6XS1	L-KOPPLING RAM R6XS	L - VERSCHRAUBUNG R6
6	A47841	1	SÄHKÖSARJA , KELLUNT	WIRE HARNESS, BOOM F	ELLEDNINGSSATS, FLYT	KABELBAUM, SCHWIMMST
7	74515	2	KUUSIORUUVI ZN	HEXAGONAL SCREW M 6x	SEKANTSKRUV M 6x45	SECHSKANTSCHRAUBE M
8	72318	2	KUUSIOMUTTERI	HEXAGONAL NUT M6 N	SEKANTMUTTER M6 NY	SECHSKANTMUTTER M 6
9	71681	2	ALUSLEVY M 6	WASHER M6 DIN 440	BRICKA M 6 DIN 440	UNTERLEGSCHIEBE M 6

A34956 HYDRAULIC QUICK ATTACHMENT PLATE

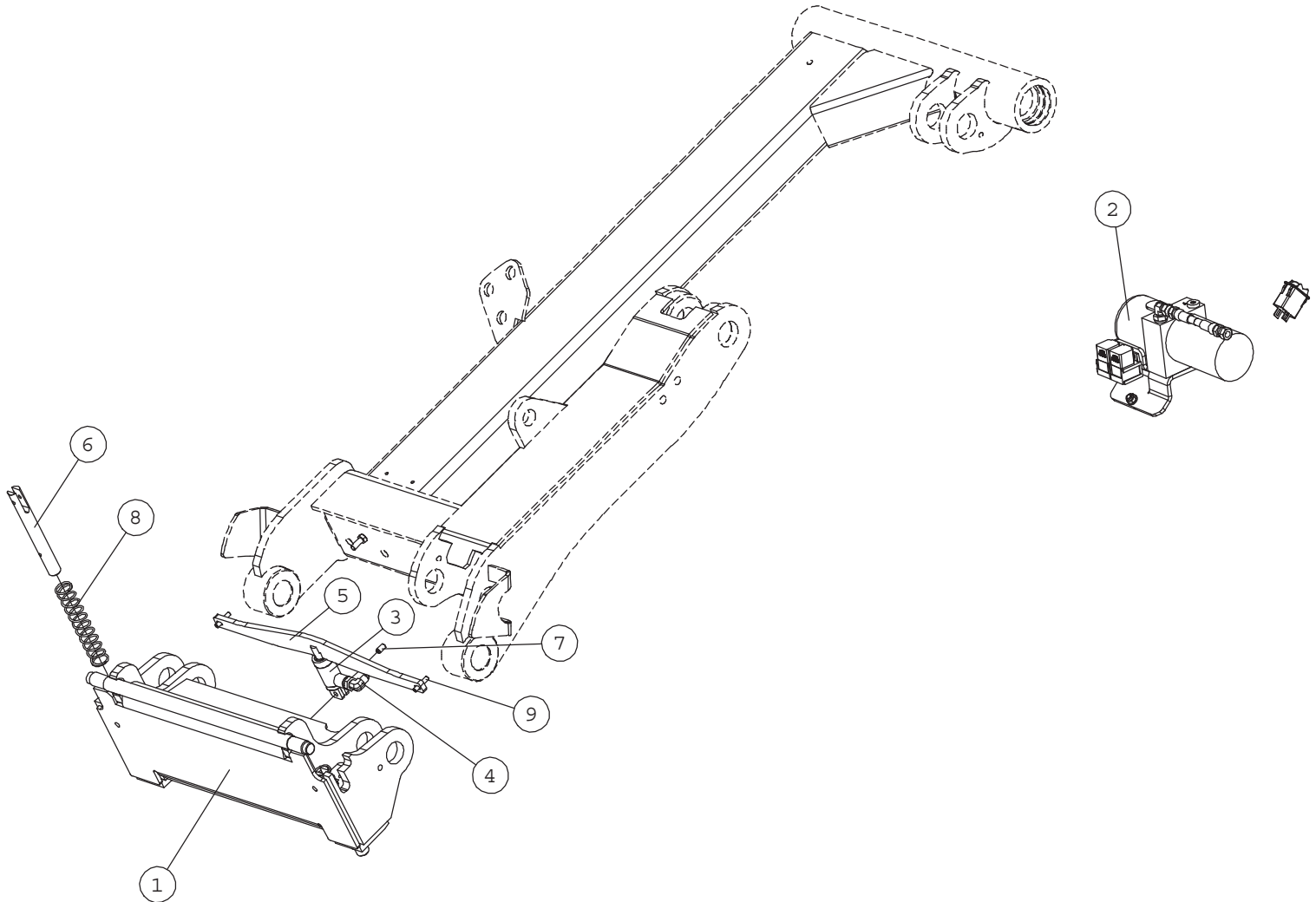

NRO REF POS TEIL	OSAN NRO PART NO BESTÄLL.NR BEST.NR	KPL QTY ST ST	NIMITYS	DESCRIPTION	BENÄMNING	BEZEICHNUNG
1	A34361	1	PIKAKIINNITYSLEVY	ATTACHMENT COUPLING	REDSKAPSFÄSTE MODELL	GERÄTEANBAUPLATTE MO
2	A34747	1	OHJAUSPAKETTI	HYDR. POWER PACK, HY	HYDRAULAGGREGAT, HYD	HYDRAULIKAGGREGAT, H
	A412059		MIKROHYDRAULIYKSIKÖN	MOUNTING PLATE, POWE	FÄSTE, HYDRAULAGGREG	AUFNHAMEPLATTE, HYDR
	65449		HYDR.KONEIKKO 12V	HYDRAULIC POWER PACK	HYDRAULAGGREGAT 12V	HYDRAULIKAGGREGAT 12
	A412507		HYDR.LETKU L=6000	HYDR. HOSE L=6000	HYDRAULSLANG L=6000	HYDR. SCHLAUCH L=60
	A34902		SÄHKÖSARJA	WIRE HARNESS, HYDR.	KABELHÄRVA, HYDR. RE	KABELBAUM, HYDR. GER
	65448		KYTKIN COBO	ROCKER SWITCH, HYDR.	VIPPBRYTARE, HYDR. R	WIPPSCHALTER, HYDR.
	64679		RELE 12V 20/30A 1-V	RELAY 12V 20/30A 1-V	RELÄ 12V 20/30A 1-V	RELÄIS 12V 20/30A 1-
3	A410776	1	HYDRAULISYLINTERI	HYDR. CYLINDER, HYDR	HYDRAULCYLINDER, HYD	HYDR. ZYLINDER, HYDR
4	64687	1	KULMALIITIN 90 AST.	ELBOW FITTING 90° C4	VINKELKOPPLING 90° C	WINKEL-VERSCHRAUBUNG
5	A410775	1	VÄLITANKO	LINKAGE ROD, HYDR. A	LÄNKSTÄNG, HYDR. RED	STANGE, HYDR. GERÄTE
6	A410803	2	LUKITUSTAPPI F20	LOCKING PIN F20, HYD	LÄSTAPP F20, HYDR. R	BOLZEN F20, HYDR. GE
7	74425	1	JOUSISOKKA	SPRING COTTER PIN 8x	FJÄDERSPRINT 8x14 DI	FEDERSPLINT 8x14 DI
8	65279	2	PURISTUSJOUSI, DIN	COMPRESSION SPRING	TRYCKFJÄDER, DIN 20	DRUCKFEDER, D
9	74455	2	JOUSISOKKA	SPRING COTTER 6x30	FJÄDERPINNE 6x30	FEDERSTIFT 6x30
10	A411085	1	TARRA	DECAL ATTACHMENT	DEKAL ATTACHMENT	AUFKLEBER ATTACHMEN
11	A411088	1	TARRA OHJE	DECAL INSTRUCTIONS	DEKAL INSTRUCTIONS	AUFKLEBER INSTRUCTI

A412225 DRIVE RELEASE VALVE
Before serial number XXXXX1342

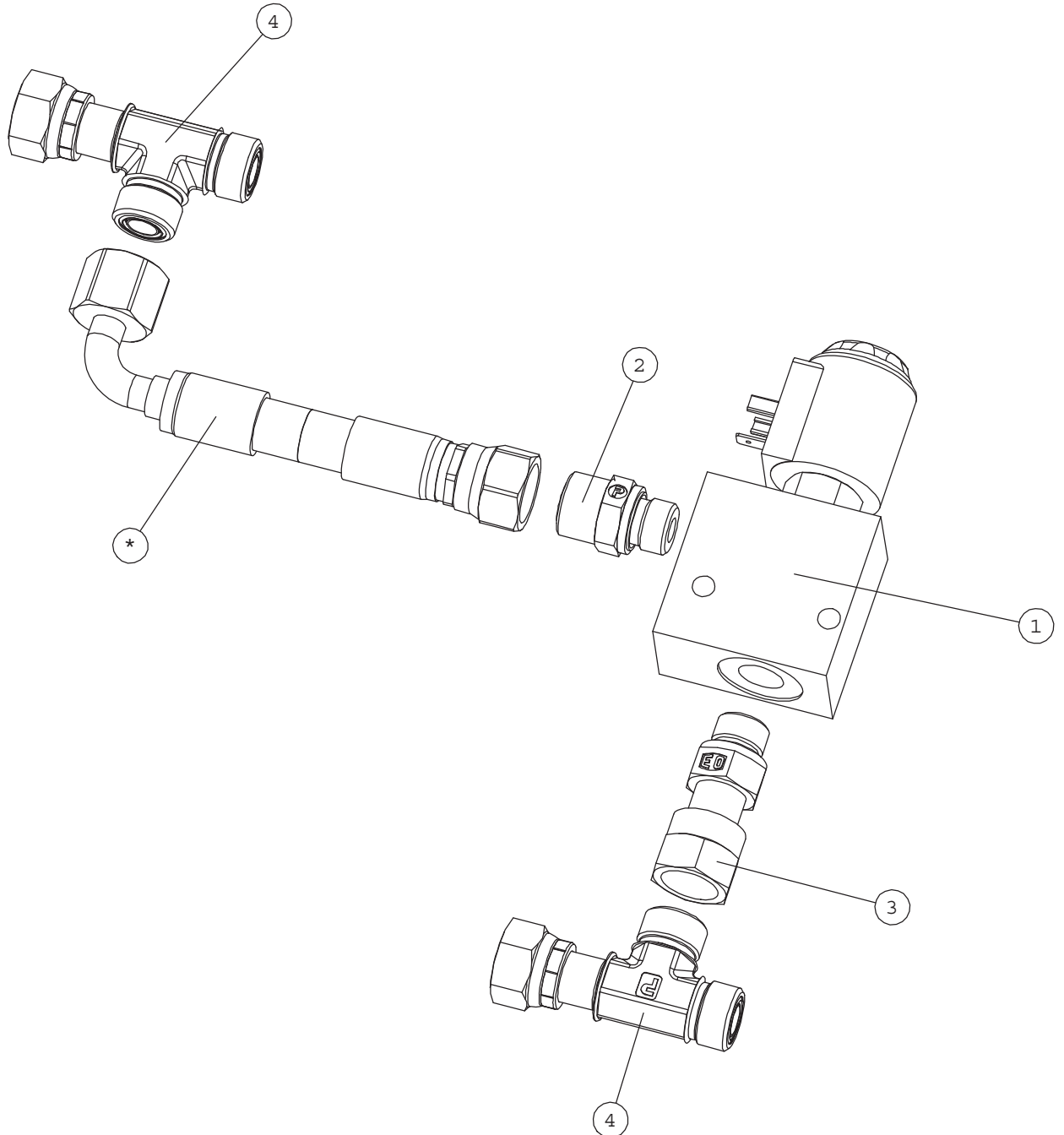

NRO REF POS TEIL	OSAN NRO PART NO BESTÄLL.NR BEST.NR	KPL QTY ST ST	NIMITYS	DESCRIPTION	BENÄMNING	BEZEICHNUNG
1	64676	1	SOLENOIDIVENTTIILI	SOLENOID VALVE WK08W	MAGNETVENTIL WK08W-0	MAGNETVENTIL WK08W-0
2	65312	1	PERUSLIITIN	BASIC FITTING 8F42ED	RAK KOPPLING 8F42EDM	GERADE EINSCHR. VERS
3	65324	1	YHDYSNIPPA	CONNECTOR NIPPLE 8F	FÖRBINDINGSNIPPEL 8	VERBINDUNGSNIPPEL 8F
4	65337	2	L-KIERRELIITINRUNKO	L FITTING 8R6MLOS	L KOPPLING 8R6MLOS	L VERSCHRAUBUNG 8R6M
5	a415114	1	HYDR.LETKU L=440	HYDR. HOSE L=440	HYDRAULSLANG L=440	HYDR. SCHLAUCH L=440

A35506 ANTI SLIP VALVE, KIT POCLAIN MOTORS

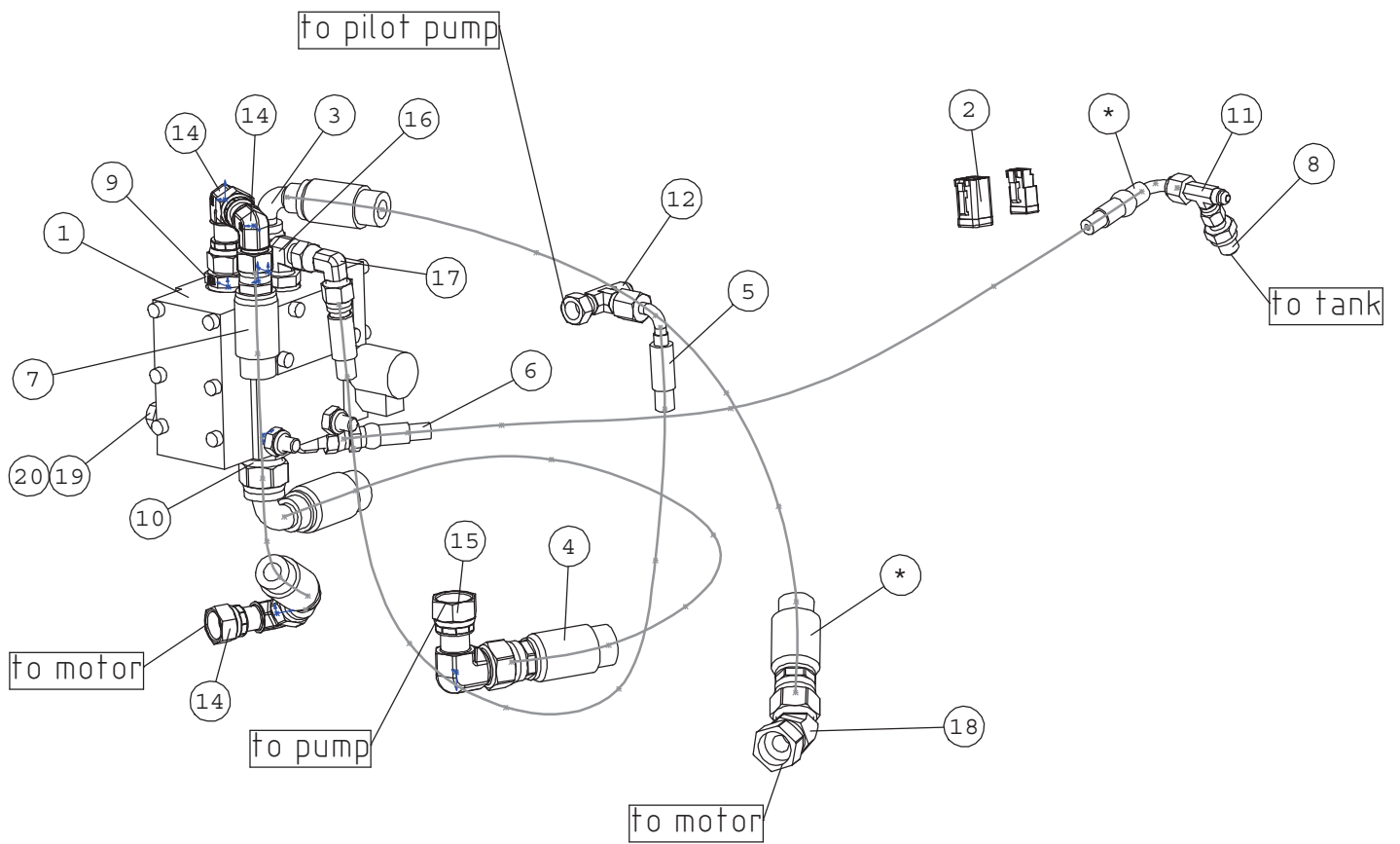
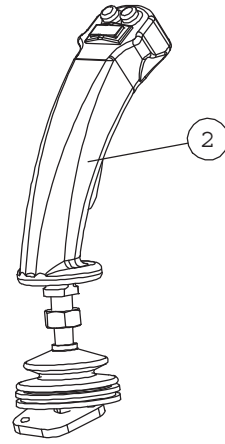

A35506 ANTI SLIP VALVE, KIT POCLAIN MOTORS

NRO REF POS TEIL	OSAN NRO PART NO BESTÄLL.NR BEST.NR	KPL QTY ST ST	NIMITYS	DESCRIPTION	BENÄMNING	BEZEICHNUNG
1	65239	1	VIRRRANJAKOVENTTIILI	FLOW DIVIDER VALVE	FLÖDESREGLERINGSVENT	MENGENREGELVENTIL
2	A410995	1	JOYSTICK KP	JOYSTICK WITH DEAD M	JOYSTICK MED DÖDMANS	JOYSTICK MIT TOTMANN
3	A415089	1	HYDR.LETKU L=680	HYDRAULIC HOSE	HYDRAULSLANG	HYDR. SCHLAUCH
4	A415091	1	HYDR.LETKU L=690	HYDRAULIC HOSE	HYDRAULSLANG	HYDR. SCHLAUCH
5	a414566	1	HYDR.LETKU L=750	HYDRAULIC HOSE	HYDRAULSLANG	HYDR. SCHLAUCH
6	A415098	1	HYDR.LETKU L=800	HYDRAULIC HOSE	HYDRAULSLANG	HYDR. SCHLAUCH
7	A415425	1	HYDR.LETKU L=380	HYDRAULIC HOSE	HYDRAULSLANG	HYDR. SCHLAUCH
8	64678	1	PERUSLIITIN	BASIC FITTING F40XS6	RAK KOPPLING F40XS6-	GERADE EINSCHR. VERS
9	65310	2	PERUSLIITIN	BASIC FITTING 8-8F42	RAK KOPPLING 8-8F42E	GERADE EINSCHR. VERS
10	65313	1	PERUSLIITIN	BASIC FITTING 10-12F	RAK KOPPLING 10-12F4	GERADE EINSCHR. VERS
11	65260	1	T-KIERRELIITINRUNKO	T FITTING	T-KOPPLING	T-VERSCHRAUBUNG
12	64078	1	L-LIITINRUNKO	L-FITTING BODY R6XS1	L-KOPPLING RAM R6XS	L - VERSCHRAUBUNG R6
13	64687	1	KULMALIITIN 90 AST.	ELBOW FITTING 90° C4	VINKELKOPPLING 90° C	WINKEL-VERSCHRAUBUNG
14	65300	3	KULMALIITIN 90 AST	ELBOW FITTING 90DEGR	VINKELKOPPLING 90GRA	WINKEL-VERSCHR. 90GR
15	65301	1	KULMALIITIN 90 AST	ELBOW FITTING 90 DGE	VINKELKOPPLING 90 GR	WINKEL-VERSCHRAUBUNG
16	64044	1	KULMALIITIN 90 AST	ELBOW FITTING 90 DE	VINKELKOPPLING 90 GR	WINKEL EINSCHR. C40X
17	64043	1	KULMALIITIN 90 AST	ELBOW FITTING 90 DE	VINKELKOPPLING 90 GR	WINKEL-VERSCHR. C6XS
18	65580	1	KULMALIITIN 45 AST.	ELBOW FITTING 45 DEG	VINKELKOPPLING 45 GR	WINKEL-VERSCHR. 45 G
19	74735	2	KUUSIORUUVI ZN	HEXAGONAL SCREW M10x	SEKANTSKRUV M10x120	SECHSKANTSCHRAUBE M1
20	72322	2	KUUSIOMUTTERI	HEXAGONAL NUT M 10 N	SEKANTMUTTER M 10 N	SECHSKANTMUTTER M10
21	72321	4	KUUSIOMUTTERI ZN	HEXAGONAL NUT M10 D	SEKANTMUTTER M10 DI	SECHSKANTMUTTER M10

A34542

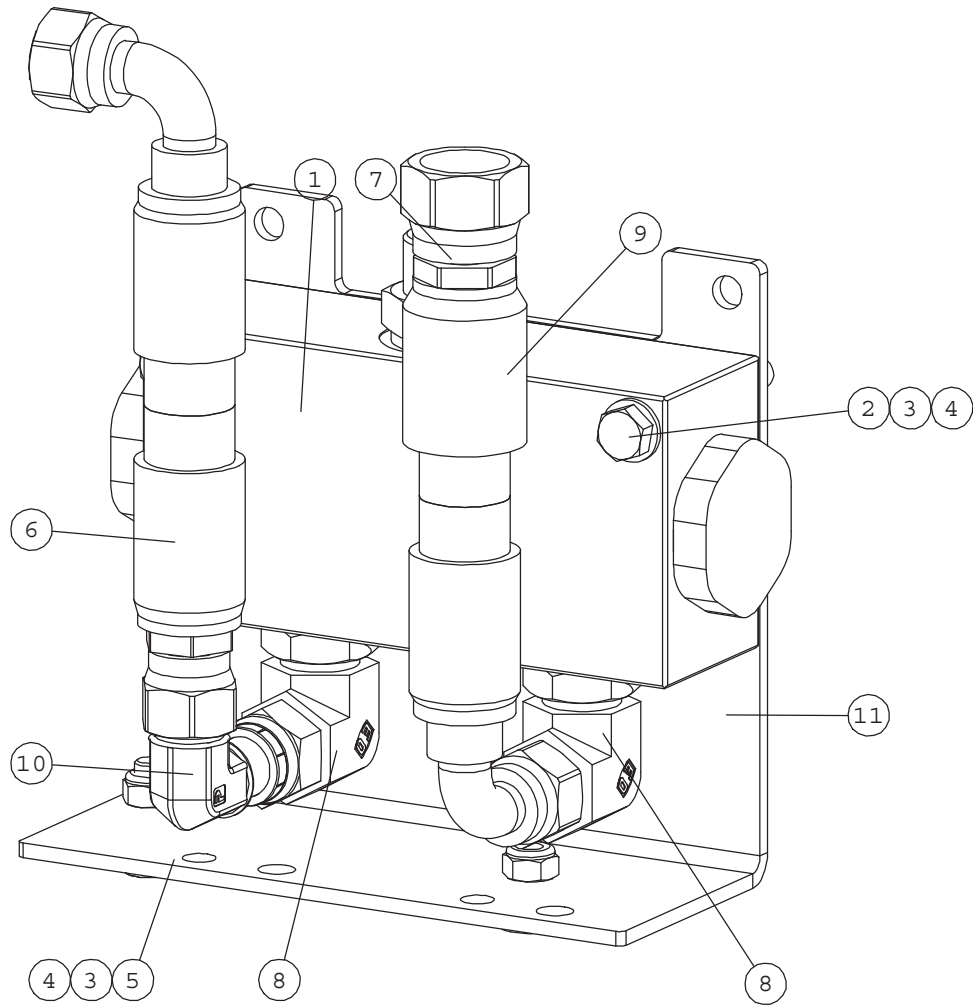
**ANTI SLIP VALVE, OMT MOTORS
FROM SERIAL NUMBER xxxxx1006**

NRO REF POS TEIL	OSAN NRO PART NO BESTÄLL.NR BEST.NR	KPL QTY ST ST	NIMITYS	DESCRIPTION	BENÄMNING	BEZEICHNUNG
1	A410193	1	VIRRANJAKOVENTTIILI	FLOW DIVIDER VALVE F	FLÖDESREGLERINGSVENT	MENGENREGELVENTIL FD
2	72141	2	KUUSIORUUVI ZN	HEXAGONAL SCREW M8x7	SEXXKANTSKRUV M8x70 D	SECHSKANTSCHRAUBE M
3	73122	6	ALUSLEVY M 8	WASHER M8 DIN 125 Z	BRICKA M8 DIN 125 Z	UNTERLEGSCHIEBE M8 D
4	72320	4	KUUSIOMUTTERI ZN	NUT M8 NYLOC DIN 98	SEXXKANTMUTTER M8 NY	SECHSKANTMUTTER M 8
5	72132	2	KUUSIORUUVI ZN	HEXAGONAL SCREW M 8	SEXXKANTSKRUV M 8x2	SECHSKANTSCHRAUBE M8
6	A411393	1	HYDR.LETKU L=300	HYDR. HOSE L=300	HYDRAULSLANG L=300	HYDR. SCHLAUCH L=300
7	65313	1	PERUSLIITIN	BASIC FITTING 10-12F	RAK KOPPLING 10-12F4	GERADE EINSCHR. VERS
8	65290	2	KULMALIITIN 90 AST	ELBOW FITTING 90 DEG	VINKELKOPPLING 90 GR	WINKEL-VERSCHRABUNG
9	A411512	1	HYDR.LETKU L=300	HYDR. HOSE L=300	HYDRAULSLANG L=300	HYDR. SCHLAUCH L=300
10	65300	1	KULMALIITIN 90 AST	ELBOW FITTING 90DEGR	VINKELKOPPLING 90GRA	WINKEL-VERSCHR. 90GR
11	A413373	1	KANNAKE	BRACKET, ANTI SLIP V	FÄSTE, ANTI SLIP VEN	AUFNAHME, ANTI SLIP

A34014 AUX. HYDR. REAR SINGLE FUNCTION

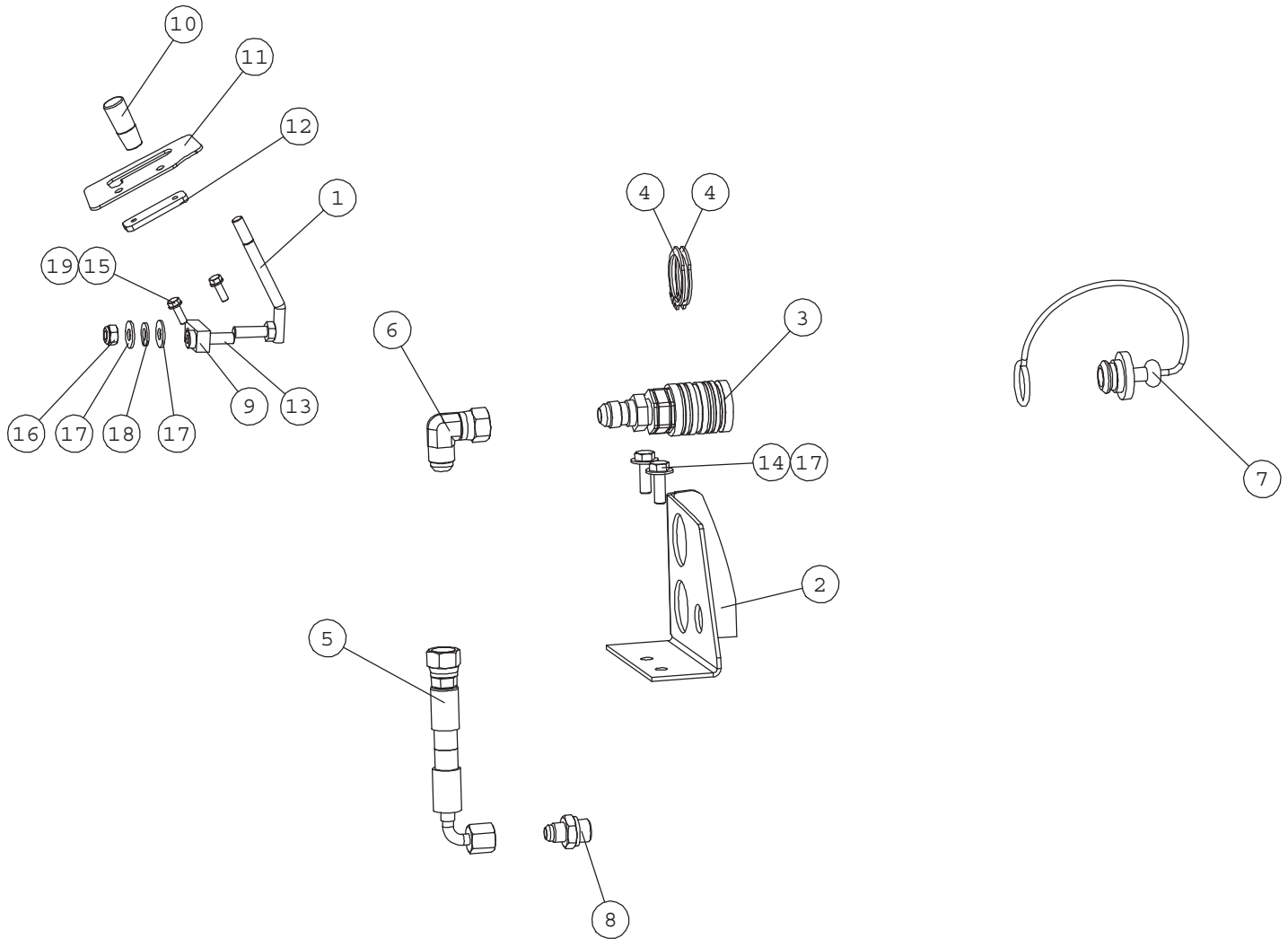

NRO REF POS TEIL	OSAN NRO PART NO BESTÄLL.NR BEST.NR	KPL QTY ST ST	NIMITYS	DESCRIPTION	BENÄMNING	BEZEICHNUNG
1	A48828	1	VIPU KP	CONTROL LEVER, AUXIL	REGLAGE, YTTRE HYDRA	BEDIENHEBEL, ZUSATZH
2	A48686	1	LÄPIVIENTILEVY	SUPPORT PLATE, QUICK	FÄSTE, SNABBKOPPLING	AUFNAHMEPLATTE, SCHN
3	64190	1	PIKALIITINRUNKO 1/2"	QUICK COUPLING PART	SNABBKOPPLINGSDEL 1/	SCHNELLKUPPLUNGSTEIL
4	74769	2	SEEGERRENGAS	SEEGER RING	SEEGER RING	HALTERING SEEGER
5	a47918	1	HYDR.LĒTKU L=3400 2L	HYDR. HOSE L=3400	HYDRAULSLANG L=3400	HYDR. SCHLAUCH L=340
6	64134	1	KULMALIITIN 90 AST	ELBOW FITTING 90 DEG	VINKELKOPPLING 90 GR	WINKEL-VERSCHR. 90 G
7	73754	1	SUOJUS MUSTA SPAV.13	RUBBER PLUG 1/2", TO	GUMMILOCK 1/2", SNAB	GUMMI-STECKER 1/2" F
8	64041	1	PERUSLIITIN	BASIC FITTING F40X	RAK KOPPLING F40XS	GERADE EINSCHR. F40X
9	a43092	1	VÄLIKAPPALE	CONNECTING PIECE, CO	FÖRBINDNINGSDEL, REG	VERBINDUNGSSTÜCK, BE
10	74761	1	NUPPI HYDR.VIPUUN	KNOB, CONTROL LEVER	KNOPP, REGLAGE	KNOPF, BEDIENHEBEL
11	A48498	1	LUKITUSHAHLO	LOCKING PLATE, CONTR	LÄSPLATTA, REGLAGE	VERRIEGELUNGSKULISSE
12	A48360	1	LUKITUSPALA	LOCKING PIECE	LÄSSTYCKE	VERRIEGELUNGSSTÜCK
13	73100	1	KUUSIOKOLORUUVI	HEXAGONAL SCREW M8x3	SEXKANTHÄLSKRUV M8x3	INNENSECHSKANT - SCH
14	72132	2	KUUSIORUUVI ZN	HEXAGONAL SCREW M 8	SEXKANTSKRUV M 8x2	SECHSKANTSCHRAUBE M8
15	72110	2	KUUSIORUUVI ZN	HEX. SCREW M5x16 DIN	SEXKANTSKRUV M5x16 D	SECHSKANTSCHRAUBE M5
16	72320	1	KUUSIOMUTTERI ZN	NUT M8 NYLOC DIN 98	SEXKANTMUTTER M8 NY	SECHSKANTMUTTER M 8
17	74525	4	ALUSLEVY M 8	WASHER M8 8,4x20x1,	BRICKA M8 8,4x20x1,	UNTERLEGSCHIBE M8
18	73962	1	ALUSLEVY M 8	WASHER M 8 DIN 127	BRICKA M 8 DIN 127	UNTERLEGSCHIBE M 8
19	74448	2	ALUSLEVY M 5	WASHER M5 A5,3 DIN	BRICKA M5 A5,3 DIN	UNTERLEGSCHIBE M5

A47774 AUX. HYDR. REAR DOUBLE FUNCTION

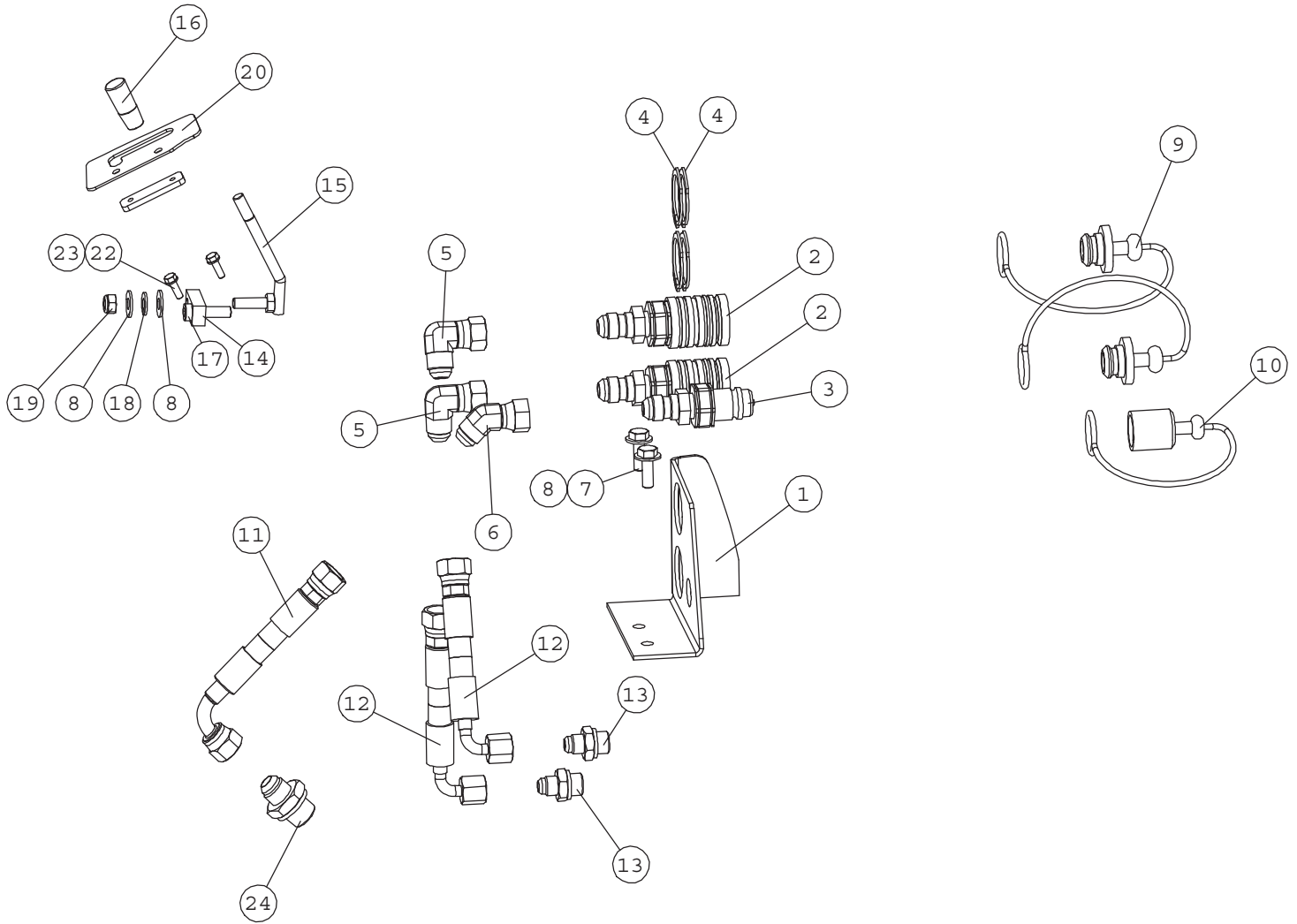

NRO REF POS TEIL	OSAN NRO PART NO BESTÄLL.NR BEST.NR	KPL QTY ST ST	NIMITYS	DESCRIPTION	BENÄMNING	BEZEICHUNG
1	A48686	1	LÄPIVIENTILEVY	SUPPORT PLATE, QUICK	FÄSTE, SNABBKOPPLING	AUFNAHMEPLATTE, SCHN
2	64190	2	PIKALIITINRUNKO 1/2"	QUICK COUPLING PART	SNABBKOPPLINGSDEL 1/	SCHNELLKUPPLUNGSTEIL
3	64189	1	PIKALIITINNIPPA 1/2"	QUICK COUPLING MALE	SNABBKOPPLINGSNIPPEL	SCHNELLKUPPLUNG STEC
4	74769	4	SEEGERRENGAS	SEEGER RING	SEEGER RING	HALTERING SEEGER
5	64134	2	KULMALIITIN 90 AST	ELBOW FITTING 90 DEG	VINKELKOPPLING 90 GR	WINKEL-VERSCHR. 90 G
6	64884	1	KULMALIITIN 45 AST.	ELBOW FITTING 45 DEG	VINKELKOPPLING 45 GR	WINKEL-VERSCHRAUBUNG
7	72132	2	KUUSIORUUVI ZN	HEXAGONAL SCREW M 8	SEKKANTSKRUV M 8x2	SECHSKANTSCHRAUBE M8
8	74525	4	ALUSLEVY M 8	WASHER M8 8,4x20x1,	BRICKA M8 8,4x20x1,	UNTERLEGSCHIEBE M8
9	73754	2	SUOJUS MUSTA SPAV.13	RUBBER PLUG 1/2", TO	GUMMILOCK 1/2", SNAB	GUMMI-STECKER 1/2" F
10	73753	1	SUOJUS MUSTA SPAV.13	COVER 1/2" TO MALE Q	HATT 1/2" TILL SNABB	HUT 1/2", SCHNELLKUP
11	A47917	1	HYDR.LETKU L=1600	HYDR. HOSE L=1600	HYDRAULSLANG L=1600	HYDR. SCHLAUCH L=160
12	a47918	2	HYDR.LETKU L=3400 2L	HYDR. HOSE L=3400	HYDRAULSLANG L=3400	HYDR. SCHLAUCH L=340
13	64041	2	PERUSLIITIN	BASIC FITTING F40X	RAK KOPPLING F40XS	GERADE EINSCHR. F40X
14	a43092	1	VÄLIKAPPALE	CONNECTING PIECE, CO	FÖRBINDINGSDEL, REG	VERBINDUNGSSTÜCK, BE
15	A48828	1	VIPU KP	CONTROL LEVER, AUXIL	REGLAGE, YTTRE HYDRA	BEDIENHEBEL, ZUSATZH
16	74761	1	NUPPI HYDR.VIPUUN	KNOB, CONTROL LEVER	KNOPP, REGLAGE	KNOPF, BEDIENHEBEL
17	73100	1	KUUSIOKOLORUUVI	HEXAGONAL SCREW M8x3	SEKKANTHÄLSKRUV M8x3	INNENSECHSKANT - SCH
18	73962	1	ALUSLEVY M 8	WASHER M 8 DIN 127	BRICKA M 8 DIN 127	UNTERLEGSCHIEBE M 8
19	72320	1	KUUSIOMUTTERI ZN	NUT M8 NYLOC DIN 98	SEKKANTMUTTER M8 NY	SECHSKANTMUTTER M 8
20	A48498	1	LUKITUSHAHLO	LOCKING PLATE, CONTR	LÄSPLATTA, REGLAGE	VERRIEGELUNGSKULISSE
21	A48360	1	LUKITUSPALA	LOCKING PIECE	LÄSSTYCKE	VERRIEGELUNGSSTÜCK
22	72110	2	KUUSIORUUVI ZN	HEX. SCREW M5x16 DIN	SEKKANTSKRUV M5x16 D	SECHSKANTSCHRAUBE M5
23	74448	2	ALUSLEVY M 5	WASHER M5 A5,3 DIN	BRICKA M5 A5,3 DIN	UNTERLEGSCHIEBE M5
24	64058	1	PERUSLIITIN	BASIC FITTING F40XS1	RAK KOPPLING F40XS12	GERADE EINSCHRAUBVER

A35462 EXTRA FRONT OUTLET

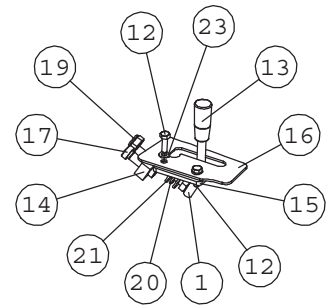
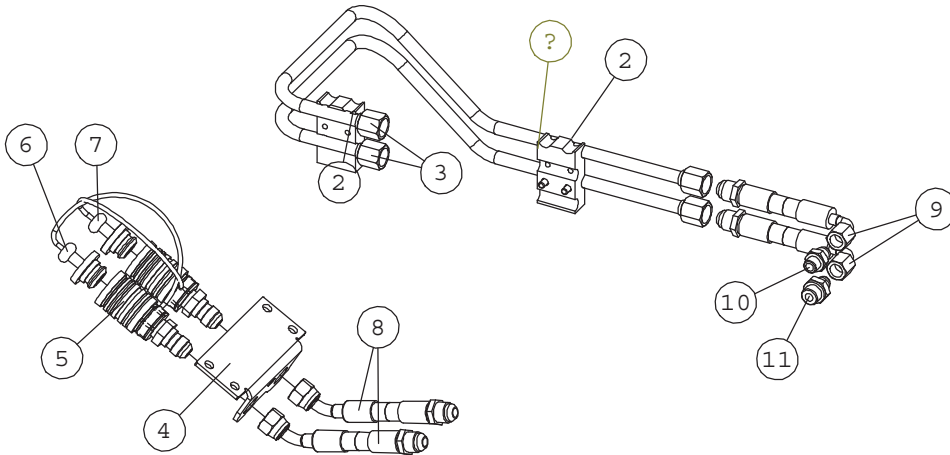

NRO REF POS TEIL	OSAN NRO PART NO BESTÄLL.NR BEST.NR	KPL QTY ST ST	NIMITYS	DESCRIPTION	BENÄMNING	BEZEICHUNG
1	A48828	1	VIPU KP	CONTROL LEVER, AUXIL	REGLAGE, YTTRE HYDRA	BEDIENHEBEL, ZUSATZH
2	a414870	2	HYDR. PUTKEN F12	PIPE CLAMP F12	RÖRKLAMMA F12	ROHRSCHELLE F12
3	A414873	2	HYDRAULIPUTKI F12	HYDRAULIC TUBE F12	HYDRAULRÖR F12	HYDRAULIKROHR F12
4	A414858	1	KIINNITYSLEVY	MOUNTING BRACKET, QU	FÄSTE, SNABBKOPPLING	AUFNAHME, SCHNELLKUP
5	64190	2	PIKALIITINRUNKO 1/2"	QUICK COUPLING PART	SNABBKOPPLINGSDEL 1/	SCHNELLKUPPLUNGSTEIL
6	73754	1	SUOJUS MUSTA SPAV.13	RUBBER PLUG 1/2", TO	GUMMILOCK 1/2", SNAB	GUMMI-STECKER 1/2" F
7	65566	1	SUOJUS SININEN SPAV.	RUBBER PLUG BLUE 1/2	GUMMILOCK BLÅ 1/2",	GUMMI-STECKER BLAU 1
8	A414877	2	HYDR.LETKU L=1300	HYDR. HOSE L=1300	HYDRAULSLANG L=130	HYDR. SCHLAUCH L=13
9	A47638	2	HYDR.LETKU L=1610 2L	HYDR. HOSE L=1610 2L	HYDRAULSLANG L=1610	HYDR. SCHLAUCH L=161
10	64059	1	PERUSLIITIN	BASIC FITTING F40XS1	RAK KOPPLING F40XS10	GERADE EINSCHR. F40X
11	64041	1	PERUSLIITIN	BASIC FITTING F40X	RAK KOPPLING F40XS	GERADE EINSCHR. F40X
12	72110	2	KUUSIORUUVI ZN	HEX. SCREW M5x16 DIN	SEXKANTSKRUV M5x16 D	SECHSKANTMUTTER M5
13	74761	1	NUPPI HYDR.VIPUUN	KNOB, CONTROL LEVER	KNOPP, REGLAGE	KNOPF, BEDIENHEBEL
14	a43092	1	VÄLIKAPPALE	CONNECTING PIECE, CO	FÖRBINDINGSDEL, REG	VERBINDUNGSSTÜCK, BE
15	A48360	1	LUKITUSPALA	LOCKING PIECE	LÄSSTYCKE	VERRIEGELUNGSSTÜCK
16	A48498	1	LUKITUSHAHLO	LOCKING PLATE, CONTR	LÄSPLATTA, REGLAGE	VERRIEGELUNGSKULISSE
17	73100	1	KUUSIOKOLORUUVI	HEXAGONAL SCREW M8x3	SEXKANTHÅLSKRUV M8x3	INNENSECHSKANT - SCH
19	72320	1	KUUSIOMUTTERI ZN	NUT M8 NYLOC DIN 98	SEXKANTMUTTER M8 NY	SECHSKANTMUTTER M 8
20	73962	1	ALUSLEVY M 8	WASHER M 8 DIN 127	BRICKA M 8 DIN 127	UNTERLEGSSCHEIBE M 8
21	74525	2	ALUSLEVY M 8	WASHER M8 8,4x20x1,	BRICKA M8 8,4x20x1,	UNTERLEGSSCHEIBE M8
22	74530	4	ALUSLEVYPARI M 6	WASHER NORDLOCK NL6	BRICKA NORDLOCK NL6	UNTERLEGSSCHEIBE NORD
23	74448	2	ALUSLEVY M 5	WASHER M5 A5,3 DIN	BRICKA M5 A5,3 DIN	UNTERLEGSSCHEIBE M5

A33658

REAR LIFTING DEVICE

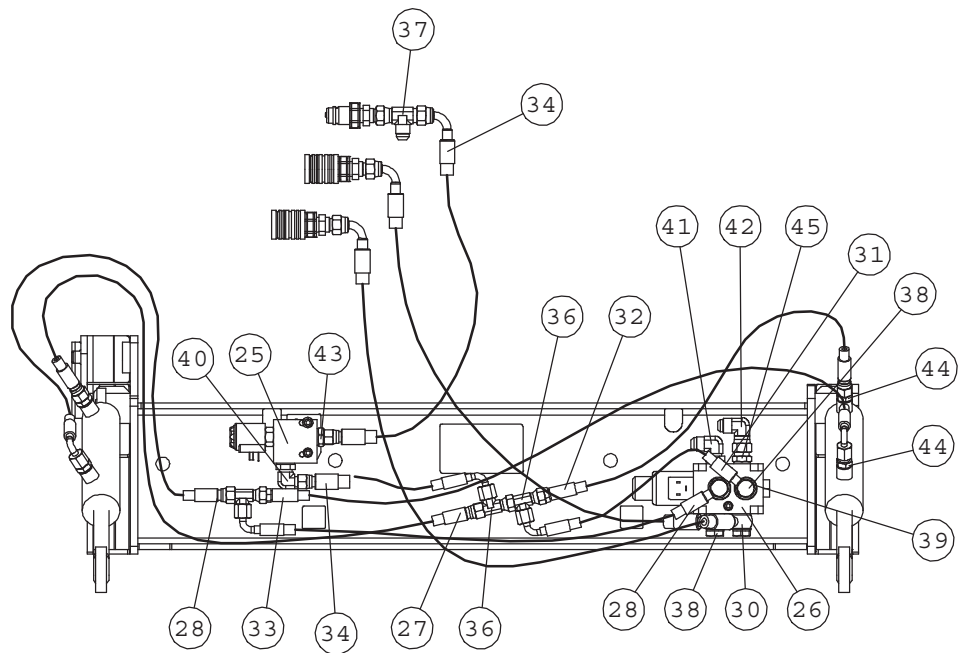
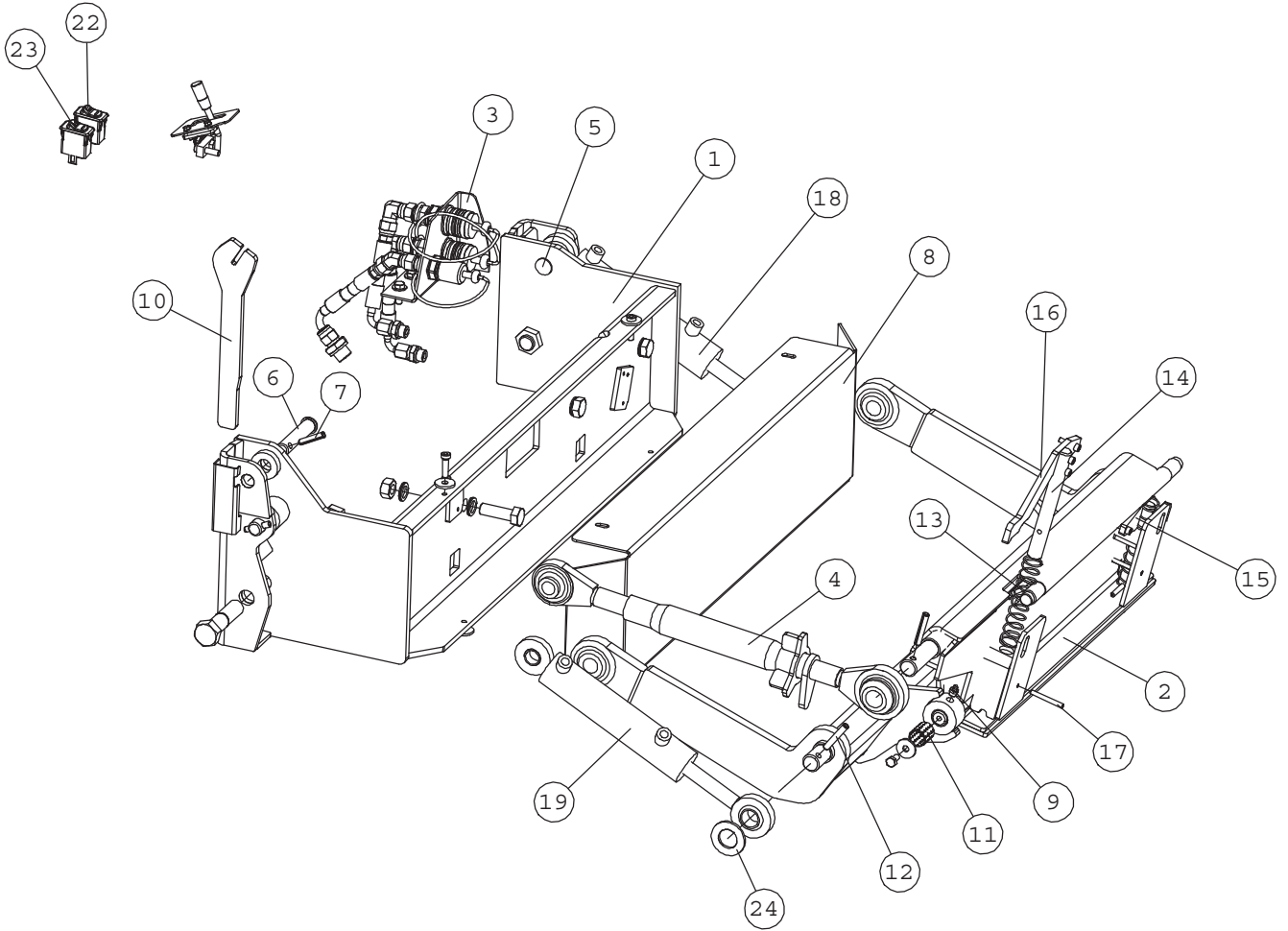

A33658 REAR LIFTING DEVICE

NRO REF POS TEIL	OSAN NRO PART NO BESTÄLL.NR BEST.NR	KPL QTY ST ST	NIMITYS	DESCRIPTION	BENÄMNING	BEZEICHNUNG
1	A33659	1	RUNKO	FRAME, HYDR. REAR LI	RAM, HYDR. BAKLYFT	RAHMEN, HYDR. HECKAU
2	A33660	1	KIINNITYSOSA	ATTACHMENT COUPLING	REDSKAPFASTA, HYDR.	GERÄTEANBAUPLATTE, H
3	A47774	1	HYDR.TAKAULOSOTTO 2-	AUX. HYDR. REAR DOUB	HYDR. UTTAG BAK, DUB	HECKHYDRAULIK DOPPEL
4	a33757	1	YLÄVARSI	TOP LINK	TOPPSTÄNG	OBERLENKER
5	A48706	2	SYL. TAPPI II	PIVOT PIN, CYLINDER	TAPP	BOLZEN, ZYLINDER
6	A48707	1	TYÖNTÖVARREN TAPPI I	PIVOT PIN, TOP LINK	TAPP, TOPPSTÄNG	BOLZEN, OBERLENKER
7	71774	3	JOUSISOKKA	SPRING COTTER PIN 8x	FJÄDERSPRINT 8x40 DI	FEDERSPLINT 8x40 DIN
8	A48724	1	PEITELEVY	COVER PLATE, HYDR. R	LOCKPLATTA, HYDR. BA	DECKELPLATTE, HECKAU
9	72798	2	RASVANIPPA DIN 71412	GREASE NIPPLE R 1/8	SMÖRNIPPEL R 1/8"	SCHMIERNIPPEL R1/8
10	A48511	1	KIINTOAVAIN	SPANNER	BLOCKNYCKEL	GABELSCHLÜSSEL
11	65163	2	LIUKULAAKERI BRM-80	SLIDE BEARING	GLIDLAGER F	GLEITLAGER F25/F
12	71776	3	JOUSISOKKA	SPRING COTTER PIN 8	FJÄDERSPRINT 8x 50 D	FEDERSPLINT 8x 50 D
13	64138	2	PURISTUSJOUSI, DIN	COMPRESSION SPRIG DI	TILLHÅLLARFJÄDER DIN	DRUCKFEDER DIN 2098
14	A48859	2	LUKITUSTAPPI	LOCKING PIN, HYDR. R	LÅSTAPP, HYDR. BAKLY	VERRIEGELUNGSBOLZEN,
15	A48896	1	LUKITUSVIPU, OIK.	SIDE ARM, RIGHT, HYD	SIDOARM, HÖGER, HYDR	SEITENARM, RECHTS, H
16	A48860	1	LUKITUSVIPU	SIDE ARM, HYDR. REAR	SIDOARM, HYDR. BAKLY	SEITENARM, HYDR. HEC
17	74933	4	JOUSISOKKA	SPRING COTTER PIN	FJÄDERSPRINT 6x50	FEDERSPLINT 6x50
18	A33663	1	HYDR.SYL F40/F20-110	HYDR. CYLINDER F40	HYDRAULCYLINDER F40	HYDR. ZYLINDER F40/
19	A33756	1	HYDR.SYL F40/F20-110	HYDR. CYLINDER F40/	HYDRAULCYLINDER F40/	HYDR. ZYLINDER F40/
20	A21244	1	LETKUTUS	HYDR. HOSES, KIT, HY	HYDRAULSLANGAR, SATS	HYDR. SCHLÄUCHE, KIT
21	A34191	1	SÄHKÖSARJA	WIRE HARNESS, HYDR.	KABELHÄRVA, HYDR. BA	KABELBAUM, HYDR. HEC
22	65277	1	KYTKIN COBO	ROCKER SWITCH, FLOAT	VIPPBRYTARE, FLYTLÄG	WIPPSCHALTER, SCHWIM
23	65278	1	KYTKIN COBO	ROCKER SWITCH, HYDR.	VIPPBRYTARE, HYDR. B	WIPPSCHALTER, HYDR.
24	71705	3	ALUSLEVY M27	WASHER M 27 DIN 12	BRICKA M 27 DIN 12	UNTERLEGSSCHEIBE M27

A21244 HYDRAULIC HOSES, KIT

NRO REF POS TEIL	OSAN NRO PART NO BESTÄLL.NR BEST.NR	KPL QTY ST ST	NIMITYS	DESCRIPTION	BENÄMNING	BEZEICHNUNG
25	64676	1	SOLENOIDIVENTTIILI	SOLENOID VALVE WK08W	MAGNETVENTIL WK08W-0	MAGNETVENTIL WK08W-0
26	65099	1	VALINTAVENTT DFE052/	SELECTOR VALVE DFE05	VÄLJARVENTIL DFE052/	WAHLVENTIL DFE052/6A
27	A33789	1	HYDR.LETKU L=1010 1L	HYDR. HOSE	HYDRAULSLANG	HYDR. SCHLAUCH
28	A33822	1	HYDR.LETKU L=650 1LW	HYDR. HOSE	HYDRAULSLANG	HYDR. SCHLAUCH
29	A33790	1	HYDR.LETKU L=760 1L	HYDR. HOSE	HYDRAULSLANG	HYDR. SCHLAUCH
30	A33830	2	HYDR.LETKU L=1250	HYDR. HOSE	HYDRAULSLANG	HYDR. SCHLAUCH
31	A33832	1	HYDR.LETKU L=250 1LW	HYDR. HOSE	HYDRAULSLANG	HYDR. SCHLAUCH
32	A33788	1	HYDR.LETKU L=690 1L	HYDR. HOSE	HYDRAULSLANG	HYDR. SCHLAUCH
33	A33831	1	HYDR.LETKU L=1110 1L	HYDR. HOSE	HYDRAULSLANG	HYDR. SCHLAUCH
34	A410475	1	HYDR. LETKU L=950	HYDR. HOSE	HYDRAULSLANG	HYDR. SCHLAUCH
35	A410474	1	HYDR.LETKU L=320	HYDR. HOSE	HYDRAULSLANG	HYDR. SCHLAUCH
36	64078	3	L-LIITINRUNKO	L-FITTING BODY R6XS1	L-KOPPLING RAM R6XS	L - VERSCHRAUBUNG R6
37	64050	1	L-LIITINRUNKO	L-FITTING BODY R6XS1	L-KOPPLINGSHUS R6	L-VERSCHRAUBUNG R6XS
38	73954	4	BANJOLIITIN	BANJO BOLT R3/8" L=2	BANJOBULT R3/8" L=2	BANJO-BOLZEN R3/8" L
39	73379	8	USIT-TIIVISTE R3/8"	USIT-COMPRESSION 3/8	USIT-PACKNING 3/8"	USIT-DICHTUNG 3/8"
40	64044	1	KULMALIITIN 90 AST	ELBOW FITTING 90 DE	VINKELKOPPLING 90 GR	WINKEL EINSCHR. C40X
41	64068	1	KULMALIITIN 90 AST.	ELBOW FITTING 90 DEG	VINKELKOPPLING 90 GR	WINKEL EINSCHRAUBVER
42	64134	1	KULMALIITIN 90 AST	ELBOW FITTING 90 DEG	VINKELKOPPLING 90 GR	WINKEL-VERSCHR. 90 G
43	64041	1	PERUSLIITIN	BASIC FITTING F40X	RAK KOPPLING F40XS	GERADE EINSCHR. F40X
44	64059	4	PERUSLIITIN	BASIC FITTING F40XS1	RAK KOPPLING F40XS10	GERADE EINSCHR. F40X
45	64042	1	PERUSLIITIN	BASIC FITTING F40	RAK KOPPLING F40X	GERADE EINSCHRAUBVER

A33912 ROAD TRAFFIC LIGHT KIT

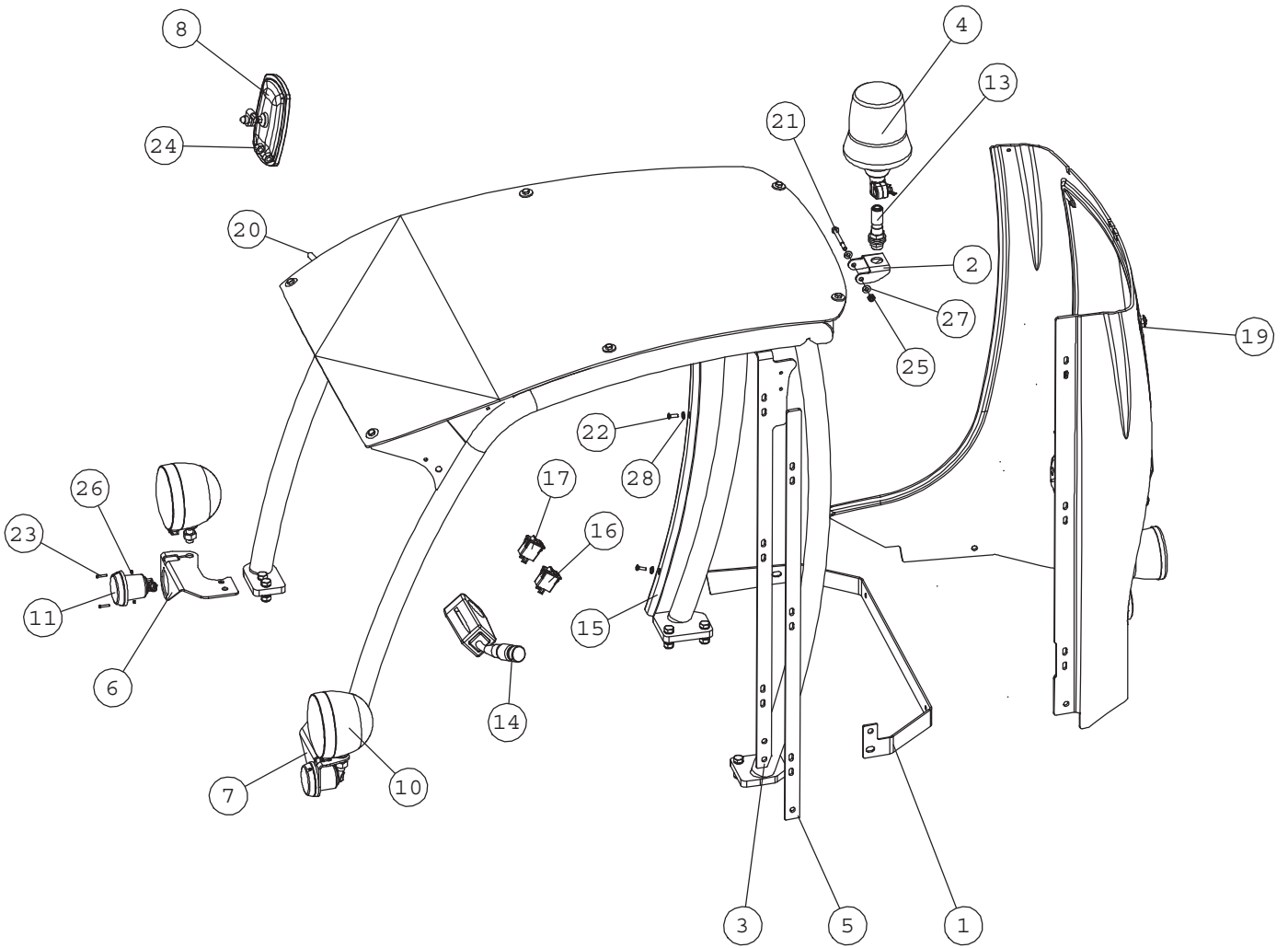

A33912 ROAD TRAFFIC LIGHT KIT

NRO REF POS TEIL	OSAN NRO PART NO BESTÄLL.NR BEST.NR	KPL QTY ST ST	NIMITYS	DESCRIPTION	BENÄMNING	BEZEICHNUNG
1	a49356	1	ALAKIINNITYSLEVY	MOUNTING BRACKET, LO	FÄSTE, LÄGRE	AUFNAHMEPLATTE, UNTE
2	A49059	1	MAJAKAN KIINNITYSLEVY	BRACKET, BEACON	FÄSTE, ALARMBLINKJU	AUFNAHME, RUNDUMLEUC
3	a49354	1	SISÄKARMI	FRAME, INNER	INRE RAM	RAHMEN, INNERER
4	64978	1	MAJAKKA COBO	BEACON 12VDC	ROTÄRANDE VARNINGSLJ	RUNDUMLEUCHTE 12VDC
5	a49353	1	ULKOKARMI	FRAME, OUTER	YTTERRAM	RAHMEN, ÄUSSERER
6	A48026	1	AJOVALONKANNAKE , OI	BRACKET, RIGHT, HEAD	FÄSTE, HÖGER, STRÄLK	AUFNAHME, RECHTS, SC
7	A48025	1	AJOVALONKANNAKE , VA	BRACKET, LEFT, HEADL	FÄSTE, VÄNSTER, STRÄ	AUFNAHME, LINKS, SCH
8	64389	1	TAUSTAPEILI 79012474	MIRROR 185x135 MM	SPEGEL 185x135 MM E-	SPIEGEL 185x135 MM
9	64401	2	HALOGEENIPOLTIN	HALOGEN BULB 12342 H	HALOGENLAMP 12342 H	HALOGENBIRNE 12342 H
10	64847	2	AJO/PYSÄK.VALAININ	HEADLIGHT/PARKING LI	STRÄLKASTARE/PARKLJU	SCHLEIFLAMPEN/PARKLIC
11	64849	2	VILKKUVALAININ	BLINKER	BLINKLJUS	BLINKER
12	A21221	1	JOHTOSARJA / TIELIIK	WIRE HARNESS, ROAD T	KABELHÄRVA, VÄGTRAFI	KABELBAUM, KOMMUNALS
13	65058	1	MAJAKAN PIDIN COBO	BRACKET (PIN), BEACO	FÄSTE (TAPP), ALARMB	AUFNAHME (ZAPFEN), R
14	64851	1	VALO/VILKKUKYTKIN	LIGHTS/BLINKERS LEVE	LJUS/BLINKSPAK	LICHT/BLINKER HEBELS
15	A49080	1	PEITELISTA SIVU	COVER STRIP, SIDE	TÄCKLIST, SIDA	ABDECKLEISTE, SEITE
16	65065	1	KYTKIN COBO	SWITCH, BEACON	BRYTARE, ALARMBLINK	SCHALTER, RUNDUMLEUC
17	65064	1	KYTKIN COBO	SWITCH, WARNING BLIN	BRYTARE, VARNINGSBLI	SCHALTER, WARNBLINKE
18	65036	1	VILKKURELE 12V 170W	BLINKER RELAY 12V	BLINKRELÄ 12V	BLINKERRELAIS 12V
19	A412565	1	TAKAMUOVI IKKUNALLA	REAR WINDOW, FOR LIG	BAKRUTA, FÖR TRAFIKS	HECKSCHEIBE MIT FENS
	A412564		TAKAMUOVI	COVER PLEAT REAR WIT	BAKSIVA UTAN FÖNSTER	HECKVERKLEIDUNG OHNE
	64733		HITAAN AJONEUVON KIL	SIGN, SLOW MOVING VE	SKYLTT FÖR LÄNGSAMT F	WARNSCHILD FÜR LANGS
	65057		HEIJASTIN PUNAINEN	REFLECTOR, RED	REFLEKTOR, RÖD	RÜCKSTRAHLER, ROT
	65263		TAKA/VILKKUVALAININ	REAR LIGHT / BLINKER	BAKLJUS / BLINKLJUS	SCHLUSSLICHT/BLINKER
	413489		TAKAIKKUNA	REAR WINDOW	BAKRUTA	HECKSCHEIBE
20	a411594	1	PEILINKANNAKE	BRACKET, MIRROR	FÄSTE, SPEGEL	AUFNAHME, SPIEGEL
21	72143	1	KUUSIORUUVI ZN	HEX. SCREW M8x80 DIN	SEKSKANTSKRUV M8x80 D	SECHSKANTSCHRAUBE M8
22	74767	3	UPPOK.RISTIURARUUVI	RAISED COUNTERSUNK H	KRYSSKRUV KULLERFÖRS	LINSENSENKSCHRAUBE M
23	74778	4	RISTIURARUUVI	PAN HEAD SCREW M3x20	KRYSSKRUV M3x20	FLACHKOPFSCHRAUBE M
24	72323	2	KUUSIOMUTTERI	HEXAGONAL NUT M12 D	SEKSKANTMUTTER M12 D	SECHSKANTMUTTER M12
25	72320	1	KUUSIOMUTTERI ZN	NUT M8 NYLOC DIN 98	SEKSKANTMUTTER M8 NY	SECHSKANTMUTTER M 8
26	74535	4	KUUSIOMUTTERI	HEXAGONAL NUT M3	SEKSKANTMUTTER M3	SECHSKANTMUTTER M3
27	73122	2	ALUSLEVY M 8	WASHER M8 A8	BRICKA M8 A8,	UNTERLEGSCHLEIBE M8
28	74768	3	ALUSLEVY MSS/NI M 6	WASHER MSS/NI M6	BRICKA MSS/NI M6	UNTERLEGSCHLEIBE MSS/

A34700 ATTACHMENT CONTROL SWITCH PACK

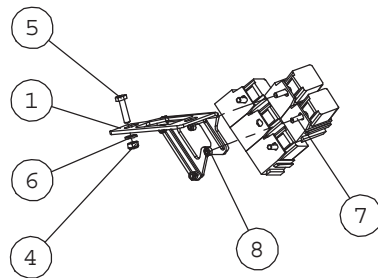
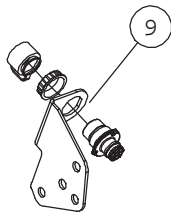

NRO REF POS TEIL	OSAN NRO PART NO BESTALL.NR BEST.NR	KPL QTY ST ST	NIMITYS	DESCRIPTION	BENÄMNING	BEZEICHNUNG
1	A411851	1	RELEKANNAKE	BRACKET, RELAY	FÄSTE, RELÄ	AUFNAHME, RELAIS
2	A34716	1	LISÄPANEELI KP	SWITCH PACK	BRYTAREPAKET	SCHALTERPAKET
3	A34689	1	SÄHKÖSARJA	WIRE HARNESS, CONTRO	KABELHÄRVA, BRYTAREP	KABELBAUM, SCHALTERS
4	72318	1	KUUSIOMUTTERI	SIXTH NUT M 6 DIN 98	SEKKANTMUTTER M6 NY	SECHSKANTMUTTER M 6
5	72119	1	KUUSIORUUVI ZN	HEXAGONAL SCREW M6x2	SEKKANTSKRUV M6x25 D	SECHSKANTSCHRAUBE M6
6	71680	1	ALUSLEVY M 6	WASHER M6 DIN 125	BRICKA M6 A6,4 DIN 1	UNTERLEGSSCHEIBE M6 A
7	72110	4	KUUSIORUUVI ZN	HEX. SCREW M5x16 DIN	SEKKANTSKRUV M5x16 D	SECHSKANTSCHRAUBE M5
8	72315	4	KUUSIOMUTTERI	NUT M 5 NYLOC DIN 9	SEKKANTMUTTER M 5	SECHSKANTMUTTER M5 N
9	a413036	1	LÄPIVIENTILEVY	BRACKET, ELECTR. OUT	FÄSTE, ELUTTAG	AUFNAHME, STECKDOSE

A33916 WORK LIGHT KIT (HALOGEN)

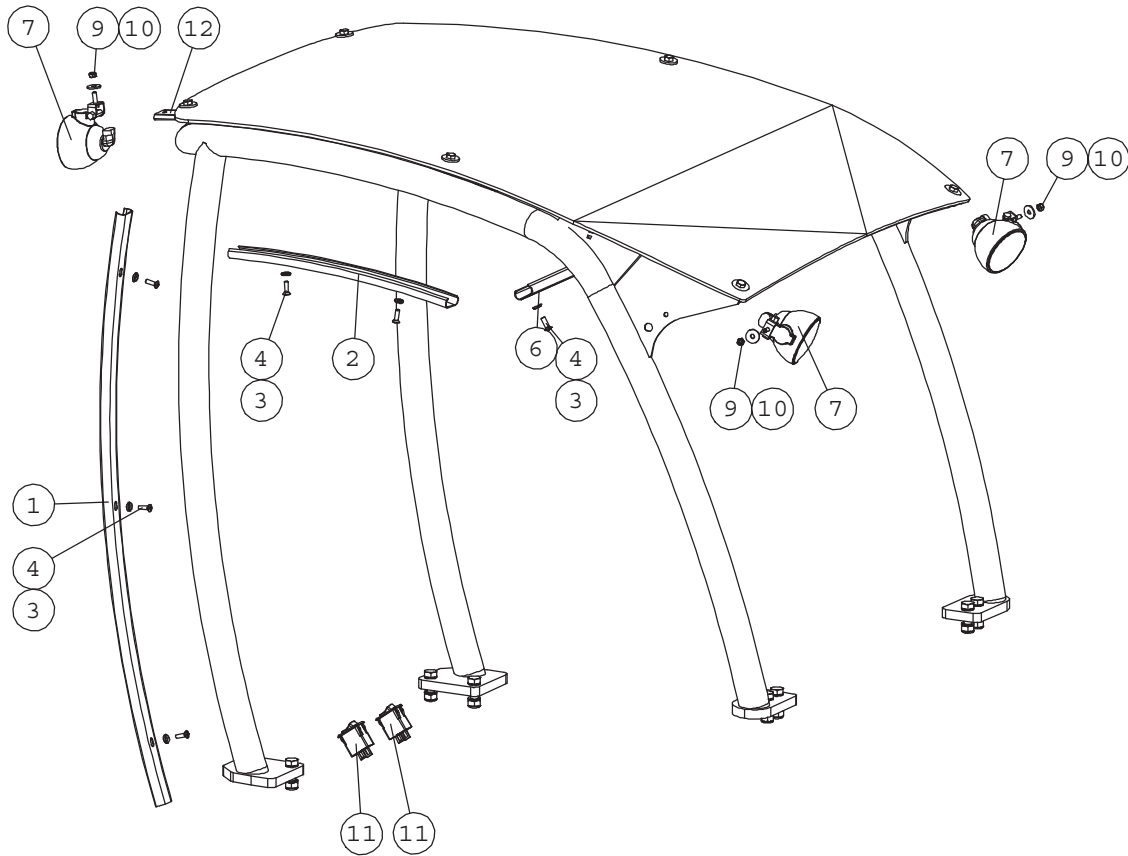

NRO REF POS TEIL	OSAN NRO PART NO BESTÄLL.NR BEST.NR	KPL QTY ST ST	NIMITYS	DESCRIPTION	BENÄMNING	BEZEICHNUNG
1	A49080	1	PEITELISTA SIVU	COVER STRIP, SIDE	TÄCKLIST, SIDA	ABDECKLEISTE, SEITE
2	A49079	1	PEITELISTA VÄLI	COVER STRIP, MIDDLE	TÄCKLIST, MELLERSTA	ABDECKLEISTE, MITTE
3	74768	8	ALUSLEVY MSS/NI M 6	WASHER MSS/NI M6	BRICKA MSS/NI M6	UNTERLEGSSCHEIBE MSS/ M 6
4	74767	8	UPPOK.RISTIURARUUVI	RAISED COUNTERSUNK H	KRYSSKRUV KULLERFÖRS	LINSENSENKSCHRAUBE M
5	A33337	1	JOHTOSARJA , TYÖVALO	WIRE HARNESS, WORK L	KABELHÄRVA , ARBETSLJ	KABELBAUM, ARBEITSLI
6	A49077	1	PEITELISTA YLÄ	COVER STRIP, UPPER	TÄCKLIST, ÖVRE	ABDECKLEISTE, OBERE
7	64965	3	TYÖVALAISIN COBO 05.	WORK LIGHT COBO 12V/	ARBETSLJUS COBO 12V/	ARBEITSLICHT COBO 12
	64874		HALOGEENIPOLTIN	HALOGEN BULB 12V/27W	HALOGENLAMPA 12V/27W	HALOGENBIRNE 12V/27W
9	72318	3	KUUSIOMUTTERI	HEXAGONAL NUT M6 N	SEXKANTMUTTER M6 NY	SECHSKANTMUTTER M 6
10	71681	3	ALUSLEVY M 6	WASHER M6 DIN 440	BRICKA M 6 DIN 440	UNTERLEGSSCHEIBE M 6
11	65066	2	KYTKIN COBO	SWITCH, WORK LIGHT	BRYTARE, ARBETSLJUS	SCHALTER, ARBEITSLIC
12	A410086	1	TYÖVALONKANNAKE	BRACKET, WORK LIGHT	FÄSTE, ARBETSLJUS	AUFNAHME, ARBEITSLIC
13	72132	1	KUUSIORUUVI ZN	HEXAGONAL SCREW M 8	SEXKANTSKRUV M 8x2	SECHSKANTSCHRAUBE M8
14	71685	2	ALUSLEVY M 8	WASHER M 8 DIN 440	BRICKA M 8 DIN 440	UNTERLEGSSCHEIBE M 8
15	72320	1	KUUSIOMUTTERI ZN	NUT M8 NYLOC DIN 98	SEXKANTMUTTER M8 NY	SECHSKANTMUTTER M 8

A34917 WORK LIGHT KIT (LED)

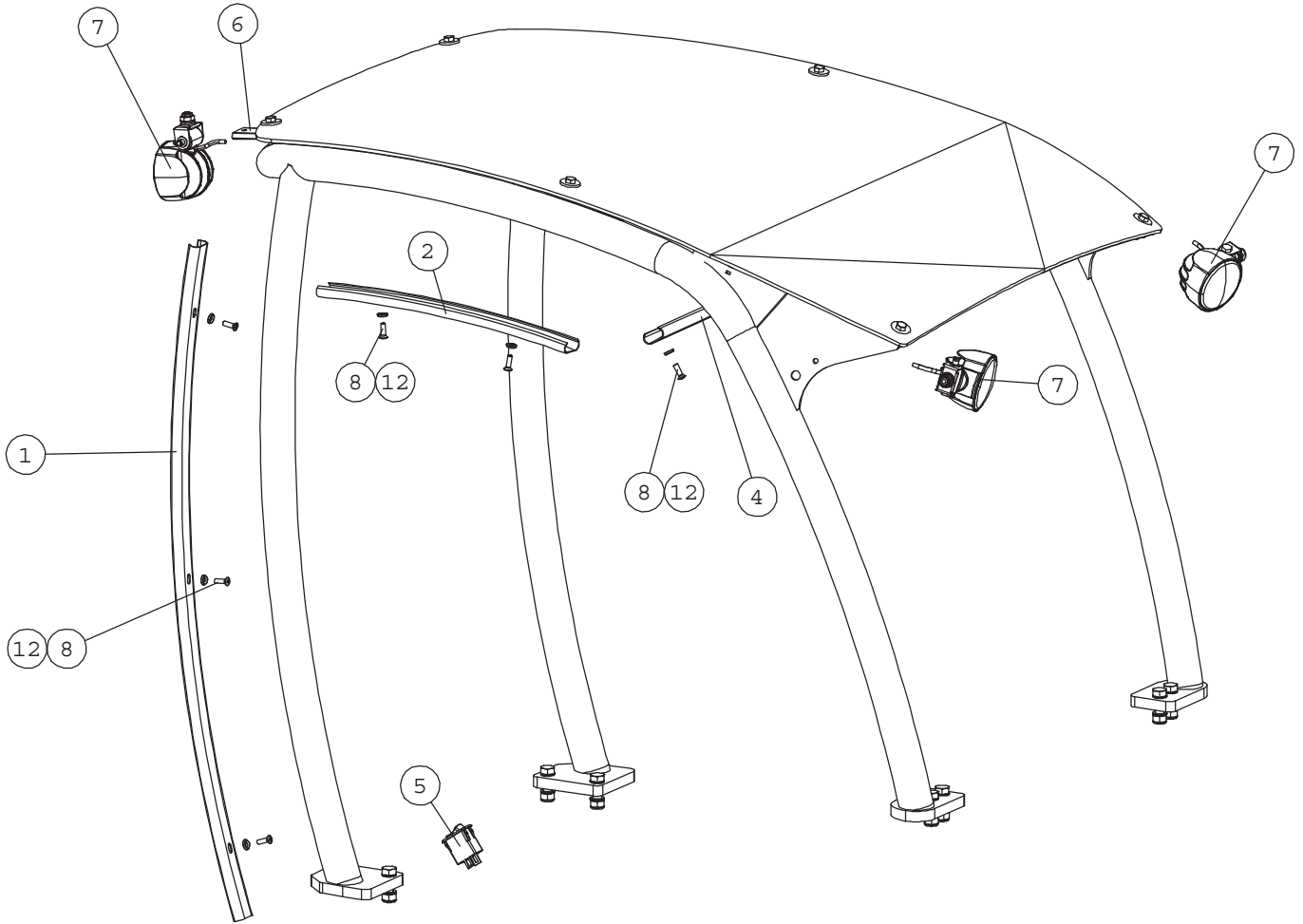

NRO REF POS TEIL	OSAN NRO PART NO BESTÄLL.NR BEST.NR	KPL QTY ST ST	NIMITYS	DESCRIPTION	BENÄMNING	BEZEICHNUNG
1	A49080	1	PEITELISTA SIVU	COVER STRIP, SIDE	TÄCKLIST, SIDA	ABDECKLEISTE, SEITE
2	A49079	1	PEITELISTA VÄLI	COVER STRIP, MIDDLE	TÄCKLIST, MELLERSTA	ABDECKLEISTE, MITTE
3	A33337	2	JOHTOSARJA , TYÖVALO	WIRE HARNESS, WORK L	KABELHÄRVA, ARBETSLJ	KABELBAUM, ARBEITSLI
4	A49077	1	PEITELISTA YLÄ	COVER STRIP, UPPER	TÄCKLIST, ÖVRE	ABDECKLEISTE, OBERE
5	65066	1	KYTKIN COBO	SWITCH, WORK LIGHT	BRYTARE, ARBETSLJUS	SCHALTER, ARBEITSLIC
6	A410086	1	TYÖVALONKANNAKE	BRACKET, WORK LIGHT	FÄSTE, ARBETSLJUS	AUFNAHME, ARBEITSLIC
7	A412571	3	LED-TYÖVALO	WORK LIGHT, LED WITH	ARBETSLJUS, LED MED	ARBEITSLICHT, LED MI
8	74767	8	UPPOK.RISTIURARUUVI	RAISED COUNTERSUNK H	KRYSSKRUV KULLERFÖRS	LINSENSENKSCHRAUBE M
9	72132	1	KUUSIORUUVI ZN	HEXAGONAL SCREW M 8	SEKKANTSKRUV M 8x2	SECHSKANTSCHRAUBE M8
10	72320	1	KUUSIOMUTTERI ZN	NUT M8 NYLOC DIN 98	SEKKANTMUTTER M8 NY	SECHSKANTMUTTER M 8
11	71685	2	ALUSLEVY M 8	WASHER M 8 DIN 440	BRICKA M 8 DIN 440	UNTERLEGSCHIEBE M 8
12	74768	8	ALUSLEVY MSS/NI M 6	WASHER MSS/NI M6	BRICKA MSS/NI M6	UNTERLEGSCHIEBE MSS/

A410648 ENGINE BLOCK HEATER

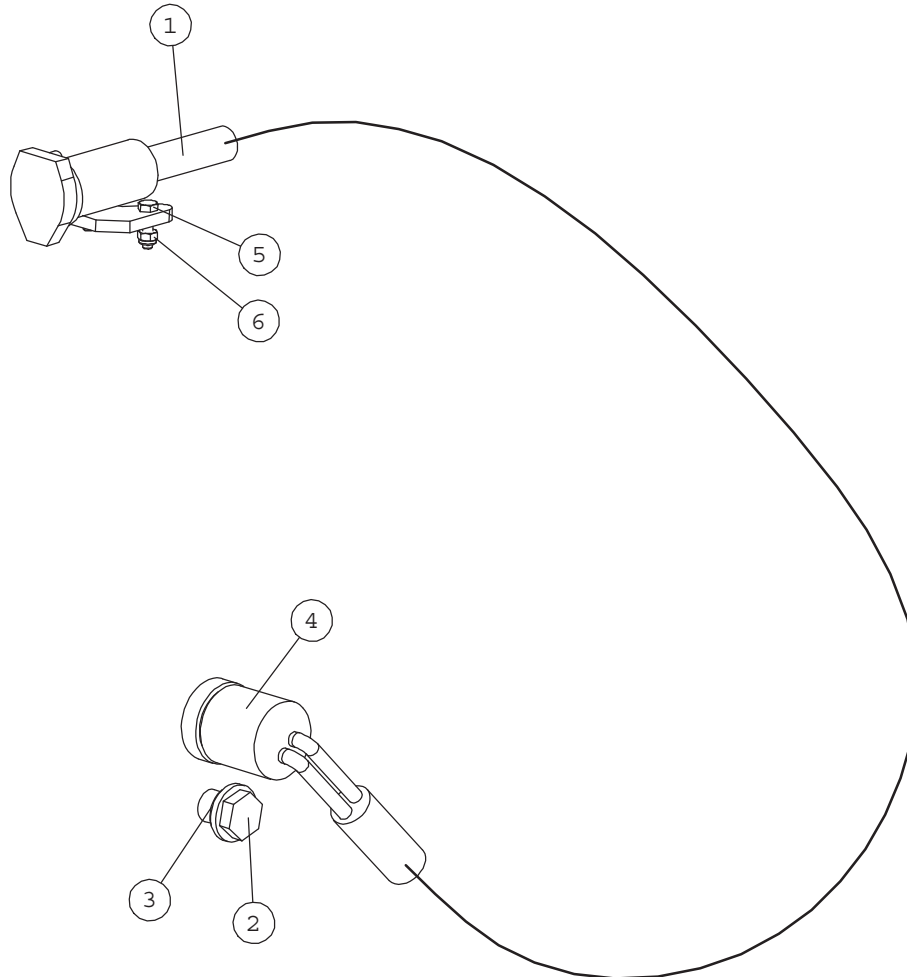

NRO REF POS TEIL	OSAN NRO PART NO BESTÄLL.NR BEST.NR	KPL QTY ST ST	NIMITYS	DESCRIPTION	BENÄMNING	BEZEICHNUNG
1	64470	1	LOHKOLÄMM ASENNUSSAR	CONNECTING LEAD DEFA	LEDNING DEFA 460992	ANSCHLUSSKABEL DEFA
2	65756	1	TULPPA KUBOTA	PLUG KUBO	PROPP KUBO	PROPFEN KUB
3	65757	1	TIIVISTE KUBOTA	SEAL K	TÄTNING KU	DICHTUNG K
4	65791	1	LOHKOLÄMMITIMEN VAS	ENGINE BLOCK HEATER	MOTORVÄRMAREELEMENT	MOTORVORWÄRMER, WIDE
5	73458	2	KUUSIORUUVI ZN	HEX. SCREW M4×16 DIN	SEKKANTSKRUV M4×16 D	SECHSKANTSCHRAUBE M4
6	72313	2	KUUSIOMUTTERI	HEXAGONAL NUT M4 DI	SEKKANTMUTTER M4 DIN	SECHSKANTMUTTER M 4
7	A46374	1	TARRA KÄYTÄ LOHKOLÄ	DECAL ENGINE BLOCK H	DEKAL MOTORVÄRMARE	AUFKLEBER MOTORVORWA

TARRAT/DECALS/DEKALER/AUFKLEBER

65024



65649



A415780



A411047



A43600



A411455



A411456



A414244



A43594



A414311



A411293



A411292



A49534



A49317



TARRAT/DECALS/DEKALER/AUFKLEBER

A48335



A48336



A415912



A417205



A410281



A410282



A416574

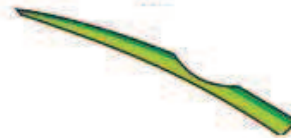

A416572



A416576



A416575



A416568



A416573



A411294



TARRAT/DECALS/DEKALER/AUFKLEBER

TARRA/DECAL	419	420	520	525	528	630	635	640	745	750	R20	R28	R35
65024	2	2	2	2	1	1	1	1	2	2	1	1	1
65649	-	-	-	-	1	1	1	1	-	-	1	1	1
A415780	1	1	1	1	1	1	1	1	1	1	1	1	1
A411047	1	1	1	1	1	1	1	1	1	1	1	1	1
A43600	1	1	1	-	1	1	-	-	1	1	1	1	1
A411217	-	-	-	1	-	-	1	1	-	-	-	-	-
A411455	1	1	1	1	1	1	1	1	-	-	-	-	-
A411456	1	1	1	1	1	1	1	1	-	-	-	-	-
A414244	1	-	-	-	-	-	-	-	-	-	-	-	-
A43594	-	1	1	-	1	1	1	1	1	1	1	1	1
A414311	2	-	-	-	-	-	-	-	-	-	-	-	-
A411293	-	1	-	-	-	-	-	-	-	-	-	-	-
A411292	-	1	-	-	-	-	-	-	-	-	-	-	-
A49534	-	-	2	-	-	-	-	-	-	-	-	-	-
A412169	-	-	-	2	-	-	-	-	-	-	-	-	-
A49317	-	-	-	-	2	-	-	-	-	-	-	-	-
A48335	-	-	-	-	-	2	-	-	-	-	-	-	-
A48336	-	-	-	-	-	-	2	-	-	-	-	-	-
A415912	-	-	-	-	-	-	-	2	-	-	-	-	-
A410281	-	-	-	-	-	-	-	-	2	-	-	-	-
A410282	-	-	-	-	-	-	-	-	-	2	-	-	-
A417205	-	-	-	-	-	-	-	-	-	-	2	-	-
A416572	-	-	-	-	-	-	-	-	-	-	-	2	-
A416576	-	-	-	-	-	-	-	-	-	-	-	-	2
A416574	-	-	-	-	-	-	-	-	-	-	1	1	1
A416575	-	-	-	-	-	-	-	-	-	-	1	1	1
A416568	1	-	1	1	1	1	1	1	1	1	1	1	1
A416573	-	-	-	-	-	-	-	-	-	-	1	1	1
A411294	-	1	-	-	-	-	-	-	-	-	-	-	-

TARRAT/DECALS/DEKALER/AUFKLEBER

A415562

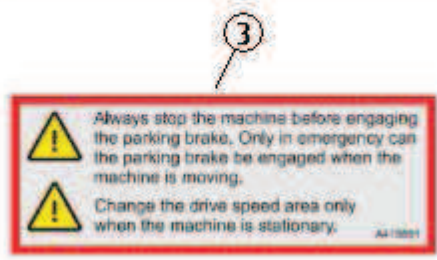
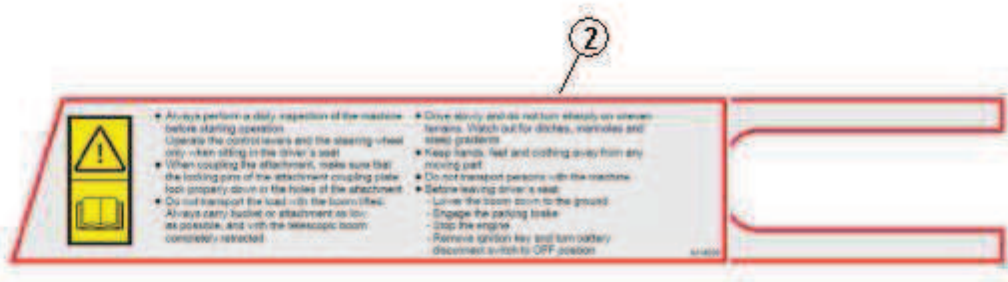

	1	2	3
suomi	A415617	A413521	A415570
English	A414664	A414690	A415591
Svenska	A414661	A414653	A415574
Deutsch	A414663	A414656	A415585